

# SILCANNEWS

ALL THE NEW KEYS, AUTOMOTIVE SOLUTIONS, KEY CUTTING MACHINES, SOFTWARE UPDATES AND MUCH MORE.

#04  
2026







## SMART PRO - NEW VEHICLE APPLICATIONS

Data update with new vehicle applications / Aggiornamento dati con nuove applicazioni veicolo / Datenaktualisierung mit neuen Fahrzeug-Anwendungen / Mise à jour des données avec des nouvelles applications de véhicules / Actualización de datos con nuevas aplicaciones de vehículos / Atualização de dados com novas aplicações de veículos

\*Silca Advanced Diagnostics software to program car keys compatible with third party makes and models. Concerning the trademarks and tradenames, please see legal note on the final page.

Region	Make	Model	Year start	Year end	Key type	SW module
Europe	Citroën	Jumper	2021	2024	BLADE	ADS2231
Africa	Renault	Duster	2017	2019	BLADE	ADS2287
Africa	Chevrolet	Lumina	2006	2011	BLADE	ADS2102
Asia	Nissan	Skyline	2015	2024	PROX	ADS2197
Australia	Jeep	Cherokee	2019	2023	SLOT	ADS2291
Australia	Fiat	500	2007	2008	BLADE	ADS2168

Silca key blanks are compatible with third party manufacturers' cylinders specified here below. Concerning the trademarks and tradenames, please see legal note on the final page.

## Proximity car key compatible with: CITROËN, DS, FIAT, OPEL, PEUGEOT, TOYOTA



**VA-A3MP65**



Make	Model	Chassis	From	To	Blade	Freq.
Citroën	Berlingo	K9	2024		HU83	433FM
Citroën	C3	B618 (VF7SX)	2020	2024	HU83	433FM
Citroën	C4 Spacetourer	-	2020	2022	HU83	433FM
Citroën	C5 Aircross	C84	2022	2025	VA2	433FM
Ds	7	X74	2022	2025	VA2	433FM
Fiat	Doblò	K9	2024		HU83	433FM
Opel	Combo	K9	2024		HU83	433FM
Peugeot	208	P21	2019	2022	HU83	433FM
Peugeot	508	R8 (VR3F)	2020	2023	VA2	433FM
Peugeot	2008	P24 (VR3U)	2019	2022	HU83	433FM
Peugeot	3008	P84 (VF3M)	2019	2022	HU83	433FM
Peugeot	5008	P87 (VF3M)	2020	2023	HU83	433FM
Peugeot	Partner	K9	2024		HU83	433FM
Peugeot	Rifter	K9	2024		HU83	433FM
Toyota	Proace City	PC-1	2024		HU83	433FM

> More info at [mykeyspro.com](https://mykeyspro.com)

Silca key blanks are compatible with third party manufacturers' cylinders specified here below. Concerning the trademarks and tradenames, please see legal note on the final page.

## ADC2025 - code D757871AD

## BYPASS CABLE SUITABLE FOR FORD



**EN** - Enables programming of replacement Ford proximity and bladed keys even in an all keys lost situation.

**IT** - Consente di programmare le chiavi di prossimità e chiavi con canna metallica Ford anche in assenza totale di chiavi.

**DE** - Ermöglicht die Programmierung von Ford Proximity- und Metallschlüsseln, auch wenn alle Schlüssel verloren gegangen sind.

**FR** - Permet de programmer des clés de remplacement Ford proximité et les clés en métal même en cas de perte totale de toutes les clés.

**ES** - Permite la programación de llaves de proximidad para Ford y de llaves sin proximidad con espadín, incluso en situación de pérdida total de llaves.

**PT** - Permite a programação de substituição de chaves proximidade e de chaves tipo lâmina Ford mesmo em caso de perda de todas as chaves.

### ADC2025 APPLICATION LIST

Make*	Model	From	To	Key Type	Silca key reference	Accessory required Add key	Accessory required (all key lost)
FORD	EXPLORER	2020	2022	Prox-Push Button	no		ADC2025
FORD	F-250 SUPER DUTY	2020	2022	Blade	no		ADC2025
FORD	F-250 SUPER DUTY	2020	2022	Prox-Push Button	no		ADC2025
FORD	F-350 SUPER DUTY	2020	2022	Blade	no		ADC2025
FORD	MUSTANG	2020	2023	Prox-Push Button	HU101AP05		ADC2025
FORD	TOURNEO CUSTOM	2019	2022	Blade	HU101R15		ADC2025
FORD	TRANSIT	2022	2026	Blade	HU101R15		ADC2025
FORD	TRANSIT CUSTOM	2019	2023	Blade	HU101R15		ADC2025
LINCOLN	NAVIGATOR	2020	2021	Prox-Push Button	no		ADC2025

### WHAT ELSE IS NEEDED?



SMART PRO



ADC2020



HU101R15



HU101AP05



**MYKEY  
Pro**

mykeyspro.com  
for installation  
support

> More info at [mykeyspro.com](https://mykeyspro.com)

Silca key blanks are compatible with third party manufacturers' cylinders specified here below. Concerning the trademarks and tradenames, please see legal note on the final page.

## ADS2269 - code D753712AD

## FORD\* KEY PROGRAMMING SW UPDATE

**EN** - First to Market all-keys-lost key programming for Ford models with an active alarm and a Continental Body Control Module.

**IT** - La prima soluzione al mondo in grado di programmare radiocomandi in caso di allarme attivo e in situazioni di perdita totale delle chiavi per modelli Ford dotato con un BCM Continental.

**DE** - First to Market, Schlüsselprogrammierung bei vollständigem Schlüsselverlust für Ford-Modelle mit aktivem Alarm und einem Continental Body Control Module.

**FR** - Première sur le Marché, programmation de clés en cas de perte totale pour les modèles Ford équipés d'une alarme active et d'un BCM Continental.

**ES** - La primera solución en el mundo capaz de programar mandos a distancia en caso de alarma activa y en situaciones de pérdida total de llaves para los modelos Ford equipados con Continental BCM.

**PT** - A primeira solução do mundo capaz de programar comandos em caso de alarme ativo e em situações de perda total das chaves para modelos Ford equipados com um módulo de controlo da carroçaria Continental (BCM).

### WHAT ELSE IS NEEDED?



SMART PRO



ADC2000



ADC2025



**EN** - Cable and key use depends on specific model / **IT** - I cavi e l'uso delle chiavi dipendono dal modello specifico / **DE** - Die Verwendung von Kabel und Schlüssel hängt vom jeweiligen Modell ab / **FR** - L'utilisation du câble et de la clé dépend du modèle spécifique / **ES** - El cable y la llave que deben usarse depende del modelo (ver carta de aplicaciones) / **PT** - A utilização de cabos e chaves depende do modelo específico.

#### OFFER DETAILS

Cable	ADC2000
Smart Aerial+ required	No
Software category	A+
Other accessories required	ADC2020, ADC2025 (certain applications only)



Refer to MYKEYS Pro for the full, uploaded application list.

> More info at [mykeyspro.com](https://mykeyspro.com)



## SMART PRO CABLES CATALOGUE

A wide range of Smart Pro accessories is available to allow key programming for hundreds of additional models.



Discover the new catalogue on Silca web site.



## HIGH-SECURITY KEYS CATALOGUE

Silca High-Security keys incorporate a series of innovative, technically advanced security solutions characterized by a high level of quality.



Discover the new version catalogue

**UPD  
2.0**

> Discover more from [Silca web site](#)

## SKP PRO 1/2026 for web subscribers

SW v. 31.11.1.x

New cutting cards and series / Nuove schede e serie / Neue Karten und Serien / Nouvelles fiches et séries / Nuevas fichas y series / Novas fichas e séries

### QCD/TRIAX PROGRAM





LOCK MANUFACTURER*	SYSTEMS*	LOCK MANUFACTURER*	SYSTEMS*
EURO LOCKS	Daken Noval (S381B) (2T-10W)	SILCA-DOM	Silca IX6SR E (Prf. 233)
EURO LOCKS	Daken Saturn GO (S545B) (2T-7W)	SILCA-DOM	Silca IX6SR E (Prf. 234)
HUF	Harley Davidson	SILCA-DOM	Silca IX6SR E (Prf. 235)
POTENT	Potent 3400F (Constructor)	SILCA-DOM	Silca IX6SR E (Prf. 240)
POTENT	Potent 3400F (Owner)	SILCA-DOM	Silca IX6SR E (Prf. 241) MK
PREFER	Prefer Serie Y (6+4)	SILCA-DOM	Silca IX6SR E (Prf.234) AT
SILCA-DOM	Silca IX6SR (Prf. 131/132) MK	SILCA-DOM	Silca IX6SR S (Prf. 250/251/252/253/254)
SILCA-DOM	Silca IX6SR E (Prf. 129/130/241) MK	SILCA-STEM	Silca Padlocks STE5 (4P)
SILCA-DOM	Silca IX6SR E (Prf. 132)	SILCA-STEM	Silca Padlocks STE6 (5P)
SILCA-DOM	Silca IX6SR E (Prf. 230/240)	SILCA-STEM	Silca Padlocks STE7 (6P)
SILCA-DOM	Silca IX6SR E (Prf. 232)	SILCA-STEM	Silca Padlocks STE8 (6P)
SILCA-DOM	Silca IX6SR E (Prf. 232/235) AT	SILCA-VACHETTE	Silca Radial NT

### CODE PROGRAM

LOCK MANUFACTURER*	SYSTEMS*
SILCA-STEM	Silca Padlocks (3P)

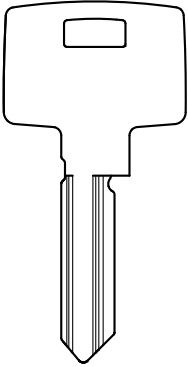
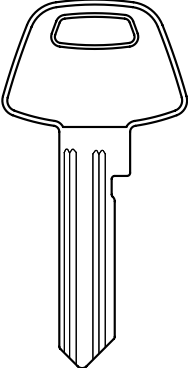
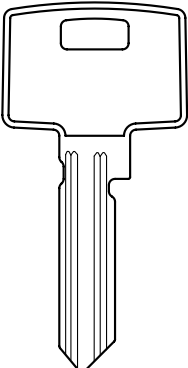
(\*) This is a trademark of a third party not affiliated nor linked with Silca S.p.A. or the dormakaba Group. Silca S.p.A. and dormakaba Group do not own any intellectual property right nor have been granted any license with regard to such trademark, which is hereby used only to indicate the intended purpose of Silca's products.

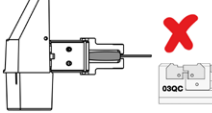
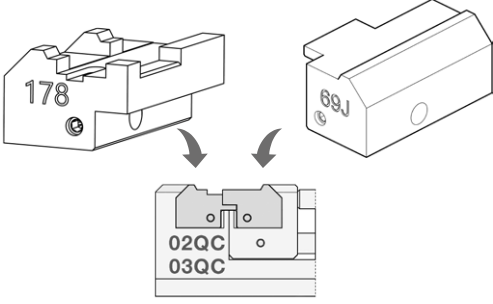
Silca key blanks are compatible with third party manufacturers' cylinders specified here below.

<p><b>ASSA* (SE)</b></p>  <p>(Assa DP Side code)</p>  <p>(Assa Neptun Side code)</p>  <p>(Assa Triton - Triton 2 Side code)</p>	 <p><b>QUATTROCODE D600</b></p> <hr/>  <p><b>QUATTROCODE D700</b></p> <hr/> 	<p><b>OPTIONAL</b> ◆ CODE</p> <p><b>D7B0314ZB</b> 178Jaw Ganascia 178 178Backe Mâchoire 178 Quijada 178 Garra 178</p> <p><b>OPTIONAL</b> ◆ CODE</p> <p><b>D747175ZB</b> 69J Jaw Ganascia 69J 69J Backe Mâchoire 69J Quijada 69J Garra 69J</p>  <p><b>OPTIONAL</b> ◆ CODE</p> <p><b>D7A8184ZB</b> Cutter 148 (carbide) Fresa 148 (metallo duro) Fräser 148 (Hartmetall) Fraise 148 (au carbure) Fresa 148 (metal duro) Fresa 148 (metal duro)</p>  <p>Assa DP</p> <p><b>D7A8201ZB</b> Cutter 324 (carbide) Fresa 324 (metallo duro) Fräser 324 (Hartmetall) Fraise 324 (au carbure) Fresa 324 (metal duro) Fresa 324 (metal duro)</p>  <p>Neptun Triton Triton 2</p> <p><b>NEW</b></p>
---	--	--

(\*) This is a trademark of a third party not affiliated nor linked with Silca S.p.A. or the dormakaba Group. Silca S.p.A. and dormakaba Group do not own any intellectual property right nor have been granted any license with regard to such trademark, which is hereby used only to indicate the intended purpose of Silca's products.

Silca key blanks are compatible with third party manufacturers' cylinders specified here below.

## ASSA\* (SE)

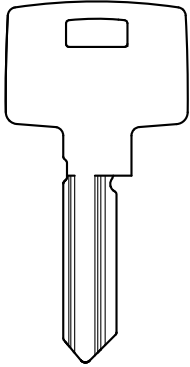

(Assa DP Side code)

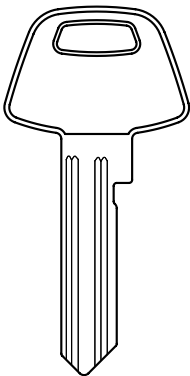

(Assa Neptun Side code)

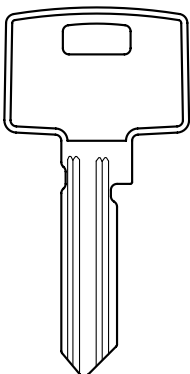

(Assa Triton - Triton 2 Side code)



**FUTURA PRO**  
≥ SW 3.54.0



**FUTURA M Series**  
≥ SW 1.1.0

### OPTIONAL



### D7B0314ZB

178Jaw  
Ganascia 178  
178Backe  
Mâchoire 178  
Quijada 178  
Garra 178

### OPTIONAL



### D747175ZB

69J Jaw  
Ganascia 69J  
69J Backe  
Mâchoire 69J  
Quijada 69J  
Garra 69J

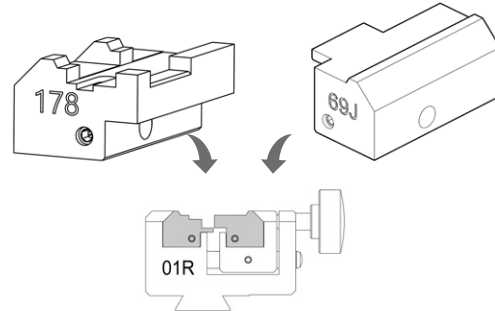

### OPTIONAL

### D751861ZB

Cutter 11LW (carbide)  
Fresa 11LW (metallo duro)  
Fräser 11LW (Hartmetall)  
Fraise 11LW (au carbure)  
Fresa 11LW (metal duro)  
Fresa 11LW (metal duro)



(\*) This is a trademark of a third party not affiliated nor linked with Silca S.p.A. or the dormakaba Group. Silca S.p.A. and dormakaba Group do not own any intellectual property right nor have been granted any license with regard to such trademark, which is hereby used only to indicate the intended purpose of Silca's products.

Silca key blanks are compatible with third party manufacturers' cylinders specified here below.

## ASSA\* (SE)

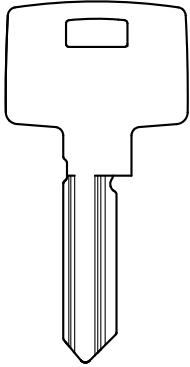

(Assa DP Side code)

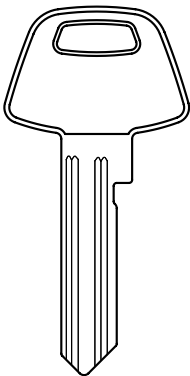

(Assa Neptun Side code)

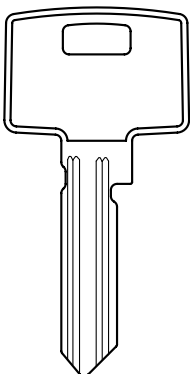

(Assa Triton - Triton 2 Side code)



**TRIAX PRO**  
≥ SW 3.0.037 DB 61.04

OPTIONAL  
◆ CODE

### D7B0314ZB

- 178Jaw
- Ganascia 178
- 178Backe
- Mâchoire 178
- Quijada 178
- Garra 178

OPTIONAL  
◆ CODE

### D747175ZB

- 69J Jaw
- Ganascia 69J
- 69J Backe
- Mâchoire 69J
- Quijada 69J
- Garra 69J

**NEW**

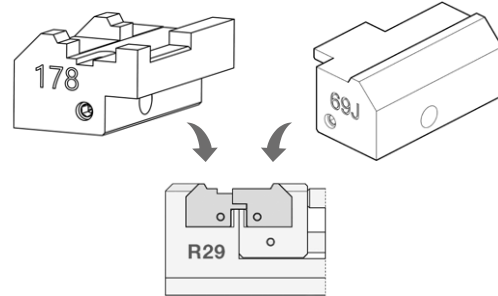

OPTIONAL **D7A8133ZB**

- Cutter W148 (carbide)
- Fresa W148 (metallo duro)
- Fräser W148 (Hartmetall)
- Fraise W148 (au carbure)
- Fresa W148 (metal duro)
- Fresa W148 (metal duro)



Assa DP

**D744060ZB**

- Cutter W324 (carbide)
- Fresa W324 (metallo duro)
- Fräser W324 (Hartmetall)
- Fraise W324 (au carbure)
- Fresa W324 (metal duro)
- Fresa W324 (metal duro)



Neptun  
Triton  
Triton 2

(\*) This is a trademark of a third party not affiliated nor linked with Silca S.p.A. or the dormakaba Group. Silca S.p.A. and dormakaba Group do not own any intellectual property right nor have been granted any license with regard to such trademark, which is hereby used only to indicate the intended purpose of Silca's products.



**LEGAL NOTES** - In compliance with current regulations relating to industrial property, please note that – but for “Silca”, “dormakaba”, “Kaba”, “Ilco” and “Advanced Diagnostics” – the trademarks or trade names mentioned in our document are the exclusive property of third parties not affiliated nor linked with Silca S.p.A. or the dormakaba Group. Silca S.p.A. and dormakaba Group do not own any intellectual property right nor have been granted any license with regard to such trademarks and trade names, which are hereby used only to indicate the intended purpose of Silca’s products. This catalogue is reserved exclusively for professional key cutters who use Silca products. The illustrations and technical data regarding the products in the document are to be considered indicative. Silca reserves the right to alter products designs, dimensions or info to improve the products quality. The contents of this document are fully protected by Copyright and may not be copied or reproduced in any form, without written permission from Silca S.p.A. For any dispute the competent Court is that of Treviso, the applicable law is that of Italy.

**NOTE LEGALI** - In ottemperanza alla normativa vigente in materia di proprietà industriale, si ricorda che – fatta eccezione per “Silca”, “dormakaba”, “Kaba”, “Ilco” e “Advanced Diagnostics” – i marchi o i nomi commerciali citati nel nostro documento sono di esclusiva proprietà di terzi, non affiliati né collegati a Silca S.p.A. o al Gruppo dormakaba. Silca S.p.A. e il Gruppo dormakaba non possiedono alcun diritto di proprietà intellettuale né agli stessi è stata concessa alcuna licenza in relazione a detti marchi o denominazioni commerciali, i quali sono qui citati solo per indicare la destinazione d’uso dei prodotti Silca. Questo catalogo è riservato esclusivamente ai duplicatori professionisti che utilizzano i prodotti Silca. Le illustrazioni e i dati tecnici dei prodotti contenuti nel documento sono puramente indicativi. Silca si riserva il diritto, ferme restando le caratteristiche essenziali dei prodotti, di apportare tutte le modifiche che ritiene necessarie e opportune al fine di migliorare la qualità dei prodotti. Tutti i disegni e le fotografie sono di proprietà di Silca, ogni riproduzione anche parziale, senza autorizzazione scritta di Silca S.p.A., è vietata secondo termini di legge. Per qualsiasi controversia il foro competente è quello di Treviso, la legge vigente è quella italiana.

**RECHTLICHE HINWEISE** - In Übereinstimmung mit den geltenden Bestimmungen zum gewerblichen Eigentum weisen wir darauf hin, dass – mit Ausnahme von “Silca”, “dormakaba”, “Kaba”, “Ilco” und “Advanced Diagnostics” – die in unserem Dokument erwähnten Markenzeichen oder Handelsnamen das ausschließliche Eigentum Dritter sind, die weder der Silca S.p.A. noch der dormakaba Gruppe angehören oder mit diesen verbunden sind. Diese Markenzeichen oder Handelsbezeichnungen werden hier nur erwähnt, um auf die bestimmungsgemäße Verwendung der Silca-Produkte hinzuweisen. Dieser Katalog ist ausschließlich professionellen Schlüsseldiensten vorbehalten, die Silca-Produkte verwenden. Die in diesem Dokument enthaltenen Abbildungen und technischen Daten der Produkte sind als Richtwerte zu betrachten. Silca behält sich vor, etwaige Änderungen, die zur Verbesserung des Produktes beitragen, vorzunehmen. Alle Zeichnungen und Fotos sind Eigentum der Firma Silca. Jede Reproduktion, auch teilweise, ist ohne ausdrückliche Genehmigung der Silca S.p.A. gesetzlich untersagt. Für alle Streitigkeiten ist das Gericht von Treviso zuständig, das geltende Recht ist italienisch.



**MENTIONS LÉGALES** - Conformément à la législation en vigueur en matière de propriété industrielle, il est rappelé que – à l’exception de “Silca”, “dormakaba”, “Kaba”, “Ilco” et “Advanced Diagnostics” – les marques ou noms commerciaux mentionnés dans notre document sont la propriété exclusive de tiers, non affiliés, ni liés à Silca S.p.A. ou au Groupe dormakaba. Ces marques ou dénominations commerciales ne sont mentionnées ici que pour indiquer la destination des produits Silca. Ce catalogue est exclusivement réservé aux reproducteurs professionnels qui utilisent les produits Silca. Les illustrations et les données techniques des produits contenus dans le document doivent être considérées comme indicatives. Bien que les caractéristiques essentielles des produits soient invariables, Silca se réserve le droit d’apporter toutes les modifications qu’elle retiendra nécessaires et opportunes afin d’améliorer la qualité de ses produits. Tous les dessins et photos sont propriété Silca et toute reproduction, même partielle, sans l’autorisation écrite préalable de Silca S.p.A. est interdite conformément aux prescriptions légales. Pour tout litige, le tribunal compétent est celui de Trévise, la loi en vigueur est italienne.

**AVISOS LEGALES** - En cumplimiento de la normativa vigente en materia de propiedad industrial, se recuerda que – salvo para “Silca”, “dormakaba”, “Kaba”, “Ilco” y “Advanced Diagnostics” – las marcas y los nombres comerciales citados en nuestro documento son propiedad exclusiva de terceras sociedades, no afiliadas ni asociadas con Silca S.p.A. o el Grupo dormakaba. Dichas marcas o denominaciones comerciales se citan aquí solamente para indicar el empleo de destino de los productos Silca. Este catálogo queda reservado exclusivamente a los duplicado-res profesionales, que utilizan los productos Silca. Las ilustraciones y los datos técnicos de los productos contenidos en el documento se han de considerar indicativos. Silca se reserva el derecho, quedando invariables las características principales de los productos, de modificar todo lo que considere necesario y oportuno para mejorar la calidad de sus artículos. Todos los dibujos y fotografías pertenecen a Silca; según determina la Ley, se prohíbe toda reproducción, total o parcial, sin autorización por escrito de Silca S.p.A. Para cualquier litigio el tribunal competente es el de Treviso, la ley vigente es la italiana.

**NOTÍCIAS LEGAIS** - No respeito das normas em vigor relativas à propriedade industrial, lembrese que – exceptuando “Silca”, “dormakaba”, “Kaba”, “Ilco” e “Advanced Diagnostics” – as marcas ou os nomes comerciais citados no nosso documento são propriedade exclusiva de terceiros, não associados nem ligados à Silca S.p.A. ou ao Grupo dormakaba. Essas marcas ou denominações comerciais são citadas aqui somente para indicar o uso pretendido dos produtos Silca. Este catálogo é reservado exclusivamente aos profissionais da duplicação que utilizam os produtos Silca. As figuras e as características técnicas dos produtos contidas no documento são facultadas a título indicativo. Mesmo que as características essenciais dos produtos sejam invariáveis, à Silca reserva-se o direito de modificar ser necessário e oportuno los productos, afim de melhorar a sua qualidade. Todos os desenhos e fotos são propriedade da Silca, e é proibida a sua reprodução mesmo parcial sem a autorização escrita da Silca S.p.A. conforme as prescri-ções legais. Para qualquer litígio o tribunal competente é o de Treviso, a lei vigente é a italiana.



CONNECT TO  
MYKEYS PRO



**ITALY AND OTHER COUNTRIES**

**SILCA S.p.A.**

Via Podgora, 20 (Z.I.)  
31029 VITTORIO VENETO (TV)  
Phone +39 0438 9136  
Fax +39 0438 913800  
E-mail: [silca@silca.it](mailto:silca@silca.it)  
Italy: [www.silca.it](http://www.silca.it)  
International Markets:  
[www.silca.biz](http://www.silca.biz)

**GERMANY**

**SILCA GmbH**

Siemensstrasse, 33  
42551 VELBERT  
Phone: +49 2051 2710  
Fax +49 2051 271172  
E-mail: [info@silca.de](mailto:info@silca.de)  
[www.silca.de](http://www.silca.de)

**FRANCE**

**SILCA S.A.S**

12, Rue de Rouen  
Z.I. Limay-Porcheville  
78440 PORCHEVILLE  
Phone: +33 1 30983500  
Fax +33 1 30983501  
E-mail: [info@silca.fr](mailto:info@silca.fr)  
[www.silca.fr](http://www.silca.fr)

**SPAIN**

**SILCA KEY SYSTEMS S.A.**

Avinguda Conflent, 52 Nave 7  
08915 BADALONA  
Phone: +34 93 4981400  
E-mail: [silca@silca.es](mailto:silca@silca.es)  
[www.silca.es](http://www.silca.es)

**BENELUX**

**H. CILLEKENS & B.V.**

Metaalweg, 4  
6045 JB ROERMOND  
Phone: +31 475 325147  
Fax +31 475 323640  
E-mail: [info@hcillekens.nl](mailto:info@hcillekens.nl)  
[www.hcillekens.nl](http://www.hcillekens.nl)

**UNITED KINGDOM**

**SILCA LTD. & ADVANCED  
DIAGNOSTICS Ltd.**

Eastboro Fields  
Hemdale Business Park  
CV11 6GL Nuneaton  
United Kingdom  
[www.silca.co.uk](http://www.silca.co.uk)



dormakaba Group