



# REKORD *PRO*

Operating Manual  
Translation of original instructions

EN

**D4A5515XA**

vers. 3.0

CE

UK  
CA



© 2022 SILCA S.p.A - Vittorio Veneto

This manual has been drawn up by SILCA S.p.A.

All rights reserved. No part of this publication can be reproduced or circulated by any means whatsoever (photocopies, microfilm or other) without the consent of SILCA S.p.A.

Edition: July 2022

Printed at Vittorio Veneto

by SILCA S.p.A.

Via Podgora, 20 (Z.I.)

31029 VITTORIO VENETO (TV) - Italy

*The Manufacturer declines any responsibility for possible inaccuracies in this document due to printing or transcription errors. The Manufacturer reserves the rights to alter the information without prior notice, except when they affect safety. This document or any of its parts cannot be copied, altered or reproduced without written authorization from the Manufacturer. Keep the manual and look after it for the entire life cycle of the machine. The information has been drawn up by the manufacturer in his own language (Italian) to provide users with the necessary indications to use the key-cutting machine independently, economically and safely.*

*IMPORTANT NOTE: in compliance with current regulations relating to industrial property, we hereby state that the trade-marks or trade names mentioned in our documentation are the exclusive property of authorized manufacturers of locks and users. Said trade-marks or trade names are nominated only for the purposes of information so that any lock for which our keys are made can be rapidly identified.*

# INDEX

USE OF THE MANUAL .....	1
GENERAL WARNINGS.....	3
1 MAIN WORKING PARTS .....	4
2 MACHINE DESCRIPTION .....	5
2.1 Further Risks .....	6
2.2 Technical Data.....	6
2.3 Electric circuit .....	7
2.4 Accessories provided .....	8
3 TRANSPORT .....	9
3.1 Packing.....	9
3.2 Unpacking .....	9
3.3 Handling the machine.....	9
4 MACHINE INSTALLATION AND PREPARATION .....	10
4.1 Checking for damage .....	10
4.2 Environmental conditions .....	10
4.3 Positioning .....	10
4.4 Separate parts .....	11
4.4.1 Carriage lever handle .....	11
4.4.2 Power cable .....	11
4.5 Connection to the mains.....	11
4.6 Description of work station .....	12
5 MACHINE REGULATION AND UTILIZATION .....	13
5.1 Checking and calibration .....	13
5.2 Calibration .....	13
6 CUTTING OPERATIONS .....	16
6.1 Key cutting.....	16
6.1.1 Clamp rotation .....	17
6.1.2 Securing the keys in the clamps .....	17
6.1.3 Key cutting .....	18
6.2 Using the accessories .....	18
7 MAINTENANCE .....	20
7.1 Replacing the brush .....	20
7.2 Replacing the cutting tool .....	21
7.3 Replacing the tracer point .....	22
7.4 Access to the lower compartment .....	23
7.5 Replacing lamp feed (transformer).....	24
7.6 Replacing lamp set/lamp protection .....	25
7.7 Replacing the fuses.....	26
7.8 Regulating carriage depth .....	26
7.9 Replacing the main switch.....	27
7.10 Replacing motor on switch .....	27
7.11 Replacing and/or tightening the belt.....	28
7.12 Replacing motor/condenser .....	30
7.12.1 Replacing motor.....	30
7.12.2 Replacing condenser .....	30
8 DISPOSAL .....	32
9 ASSISTANCE.....	33
9.1 How to request service.....	33



## USE OF THE MANUAL

This manual has been drawn up by the Manufacturer and is an integral part of the machine literature. The manual gives information that is obligatory for the operator to know and which makes it possible to use the machine safely.

### User's Manual

This user's manual is provided because it is essential for proper use and maintenance of the machine. The manual must be kept carefully throughout the life of the machine, including the decommissioning stage. Keep in a dry place close to the machine where it is always to hand for the operator.



**IT IS OBLIGATORY to read the manual carefully before using the machine.**

### Readers' characteristics

This manual must be read and its contents acquired by those who will use it.

### Manufacturer's ID

REKORD PRO has an ID plate located on the back of the machine, showing the serial number.

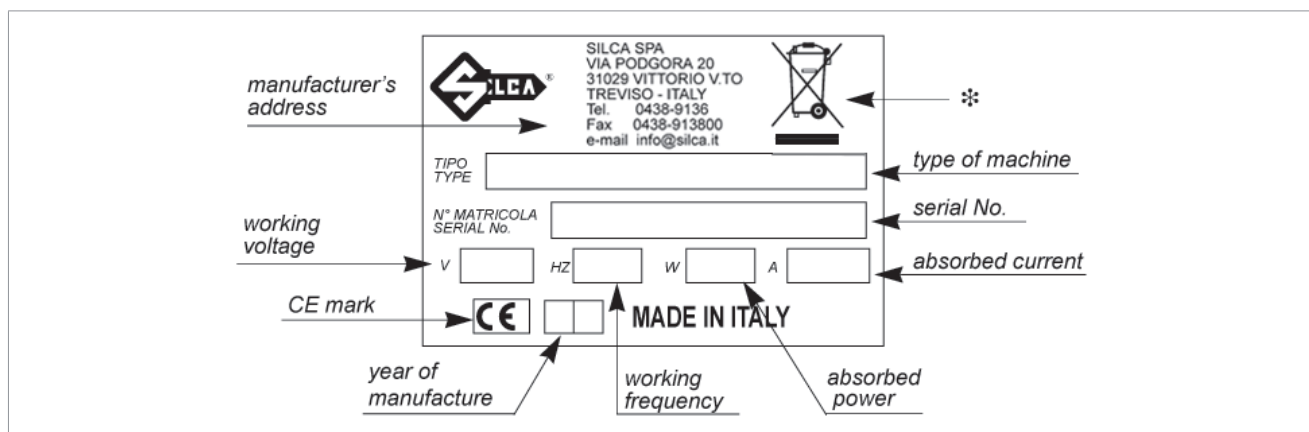

Fig. 1

(\*) see Ch. 8 DISPOSAL.

### How to apply for after-sales service

Silca provides purchasers of REKORD PRO with After-Sales Service.

For the total safety of the operator and machine, any operation not described in the manual must be carried out by the manufacturer or in the special Service Centers recommended by Silca.

At the end of the manual there is a list of manufacturers' and authorized Service Centre addresses; if the manual was downloaded is necessary visit the website to see the contacts ([www.silca.biz](http://www.silca.biz)).

The warranty card attached to the machine covers free repairs or replacement of faulty parts for 24 months from the date of purchase\*. All operations must be agreed by the user with Silca or the Service Center.

\* Damage caused by negligence or wrong use of the machine by the user will null the warranty.

### TERMINOLOGY

For those inexperienced in the subject of keys and key cutting, below is an illustration of the most frequently used terms:

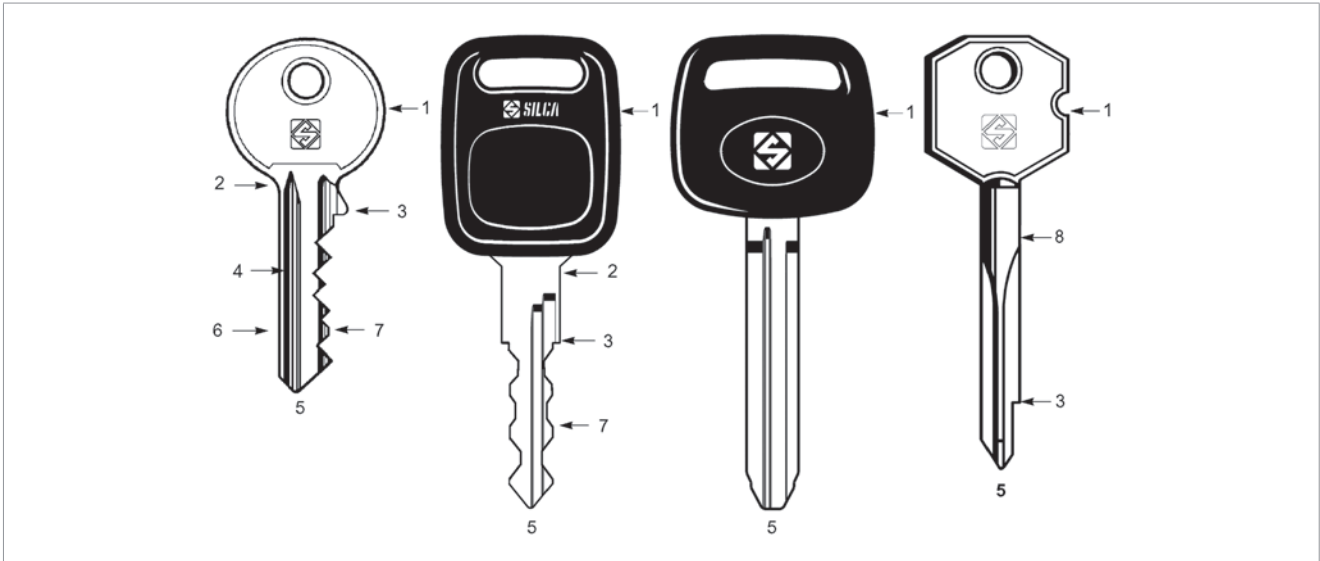

Fig. 2

1) Head	3) Shoulder stop	5) Tip	7) Cutting
2) Neck	4) Blade	6) Back	8) Stem

### GRAPHICS IN THE MANUAL

Pay attention	Obligation to read the manual	Obligatory use of otoprotectors

### GRAPHICS ON THE REKORD PRO KEY-CUTTING MACHINE

Obligatory use of safety goggles	Do not clean with compressed air	Obligation to read the manual	Cutter motor start switch

		<b>Duty: max 50%</b> <b>Continuous: max 10min</b>	
ATTENTION! GANGEROUS MOBILE PARTS Keep all body parts away from moving parts		Motor service label	Adhesive label Mass - RPM - Fuses

## GENERAL WARNINGS

REKORD PRO is designed to the principles of European Standards (CE).

Right from the design stage solutions have been adopted to eliminate hazards for the operator in all the stages of use: handling, regulation, use and maintenance.

The materials used in manufacture and the components employed in using REKORD PRO are not dangerous and ensure that the machine complies to current standards.

Silca S.p.A. has also experimented and applied numerous technical solutions that allow the key-cutting machine to optimize the quality of the cut keys.

To guarantee maintaining these results over time, please follow the instructions below:

- **Observe the procedures described in this manual;**
- **Always use Original Silca Tools as they are designed to make the best of REKORD PRO and provide quality key-cutting;**
- **Use Silca key blanks, made with top quality materials;**
- **Have the key-cutting machine checked periodically by an authorized Silca After-Sales Service Center;**
- **Always use Silca Original Spare Parts. Beware of imitations!**

## NORMAL USE

REKORD PRO is a key-cutting machine and must be installed and used according to the rules and specifications established by the manufacturer.

The key-cutting machine must be used only by skilled personnel (professional use).

The REKORD PRO key-cutting machine is designed for use on business or industrial premises (e.g. hardware shops, key cutting centers, etc...).

Any other use different from that indicated in this manual will cause the forfeiture of all customers' rights to make claims on Silca S.p.A. and may be an unknown source of hazard for the operator or third parties.



**ATTENTION: negligent use or failure by the operator to observe the instructions in this manual are not covered by the warranty and the manufacturer declines any responsibility in such cases.**

## SAFETY

REKORD PRO is built entirely to standards. The operations for which it has been designed are easily carried out at no risk to the operator.

The adoption of general safety precautions (wearing protective goggles) and observation of the instructions provided by the manufacturer in this manual eliminate all human error, unless deliberate.

The key-cutting machine is designed with features which make it completely safe in all its parts.

## FURTHER RISKS

There are further risks arising from the use of the machine (see chap.2.1).

## SAFETY REGULATIONS

- **Always disconnect the machine when it is not in use or when performing maintenance operations.**
- **Check the electrical wiring periodically; replace any wires that show signs of wear.**
- **Always work with dry hands free of grease or oil.**
- **Never tug on the electricity supply lead and make sure it is not in contact with oil or other liquids, sharp objects or heat. Never remove the grounding pin from the plug. Check that the ground wire is connected properly.**
- **Do not use the machine in dangerous environments (wet or damp).**
- **All visitors, especially children, must stay at a safe distance from the machine and must never come into contact with the electric wiring. This equipment should not be used where children may be present.**
- **The device is not suitable for use by children under the age of eight, by persons with reduced physical, sensorial or mental capacity, or lacking experience or the necessary knowledge, unless they are supervised or have been instructed in how to use the device safely and understand its inherent hazards.**
- **Do not let children play with the device.**
- **Children must not be allowed to carry out the cleaning and maintenance operations to be performed by users, unless they are supervised.**

# 1 MAIN WORKING PARTS

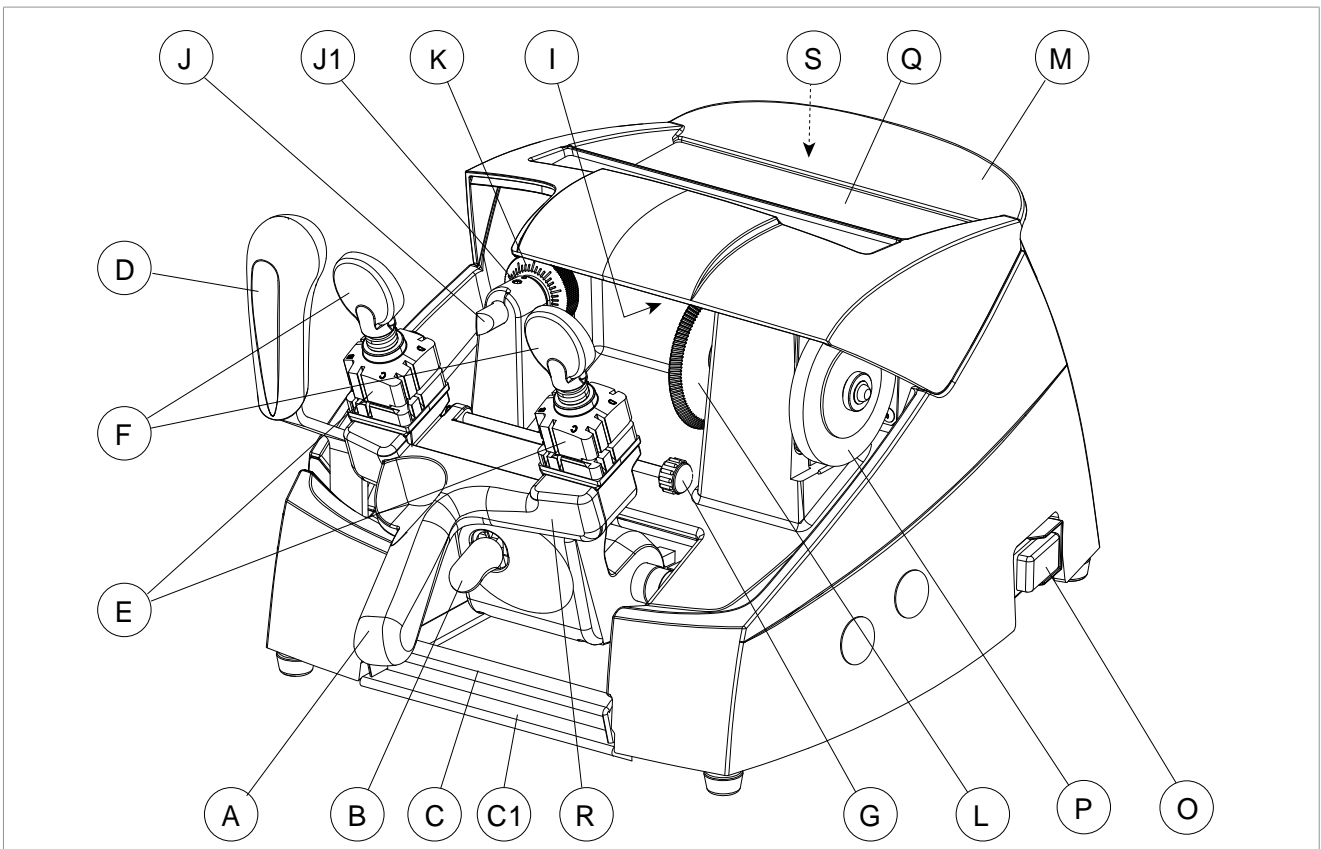

Fig. 3

- A - carriage lever handle
- B - carriage release lever
- C - chippings tray
- C1 - tool tray
- D - carriage movement lever
- E - clamps
- F - clamp knobs
- G - gauge knob
- H - gauge tabs
- I - lamp
- J - tracer point
- J1 - tracer point locking grub screw
- K - centesimal ring
- L - cutting tool
- M - top cover
- N - cutter motor start switch
- O - main switch
- P - brush
- Q - pads
- R - clamp carriage
- S - motor
- U - fuses
- V - supply socket

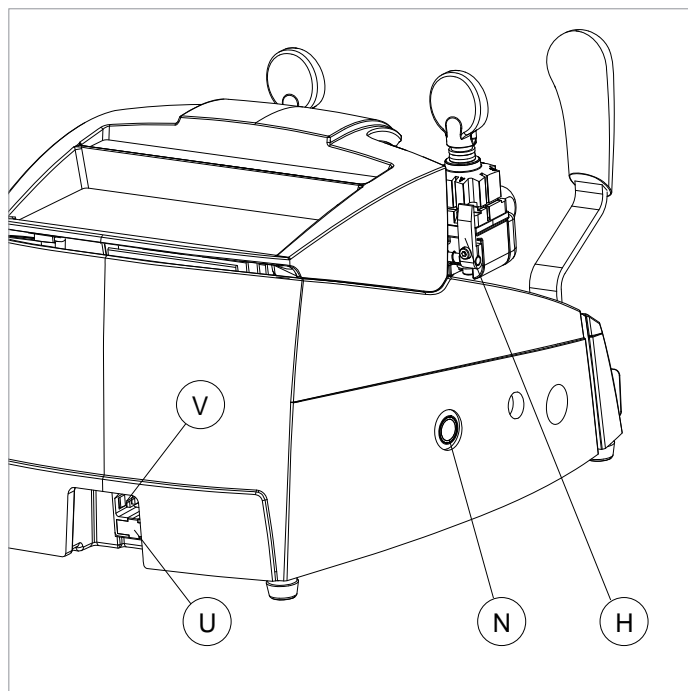

Fig. 4



## 2 MACHINE DESCRIPTION

REKORD PRO is a professional cutting machine for duplicating flat keys used with cylinder, car locks and cruciform keys. REKORD PRO is used to cut the following types of keys:



Fig. 5

The main parts of the machine are described below:

- **Main switch**

The key-cutting machine is connected to a power supply socket provided with a differential switch (chap.4.4.2 and chap.4.5). When the machine is switched on using the switch (O) on the right-hand side, the lamp (I) turns on to indicate the presence of voltage.



**ATTENTION: switch (O) is electromagnetic, in the event of a power failure it goes out automatically. When electricity is restored it must be reset manually to power the machine again by means of the plug.**

- **Motor on switch**

On the left-hand side of the motor there is the cutter motor start switch (N).

- **Motor and transmission unit**

The motor has belt transmission. The transmission unit is placed on the right of the motor and activates the brush (P) and cutting tool (L). These components are protected by the protective cover (M).

- **Clamp carriage**

The horizontal carriage (R) controlled by lever (D) has a handle (A) for front movement and holds 2 clamps (E).

- **Cutting unit**

The cutting unit contains the actual working parts of the REKORD PRO key-cutting machine, which operate together to cut and finish keys “read” from the originals. The working parts are described below:

### Cutting Tool

The cutting tool (L) is the part of the REKORD PRO used for cutting key blanks. The cutting tool is in HSS super rapid steel.

### Tracer point

The tracer point (J), dedicated to reading the cuts on keys to be copied is housed on the left-hand side of the machine. Depth is easily regulated by means of the relevant centesimal ring nut (K).

### Clamps

The clamps (E) are rotating and four-sided to allow perfect closure of the key placed on its back or profile in the case of keys with symmetrical cuts (chap.6.1).

### Clamp knobs

The clamps are locked by two anatomical knobs (F), which ensure perfect grip on the keys with only slight locking pressure.

### Gauges

Next to the clamps there is a rod with two gauge tabs (H) to control key alignment.

### Brush

The brush (P) is used to eliminate burrs from the cuts and is made of non-abrasive material. To activate the brush, turn the switch (N) on the left-hand side of the machine.

## 2.1 Further Risks



**ATTENTION:** there are residual hazards in the cutting zone (A) where the cutter is located. Carefully observe the warnings in the manual.

**ATTENTION: DANGEROUS MOBILE PARTS.** Keep all body parts away from moving parts.



To fit or remove keys from the clamp STOP THE MOVEMENT OF THE CUTTER by means of the switch (N). If this is not done the carriage may cause a hazard by going unexpectedly towards the moving cutter.

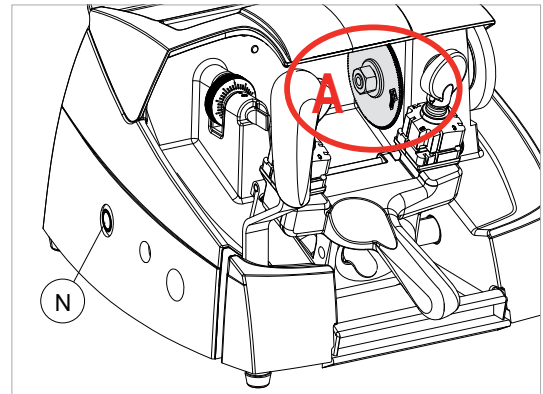

Fig. 6

## 2.2 Technical Data

<b>Power supply:</b>	230V - 50/60Hz
<b>Maximum absorbed power:</b>	230V: 390 Watt 2A
<b>Cutter motor:</b>	single phase and speed 230V-50/60Hz: 1350/1620 rpm.0,18Kw
<b>Movements:</b>	by gear on rectified carriage
<b>Clamps:</b>	rotating with four sides, high precision
<b>Cutter:</b>	HSS Super Rapid Steel - coated
<b>Runs (maximum length of cuts):</b>	43 mm
<b>Dimensions:</b>	width: 330 mm (with max. lever encumbrance 510mm) depth: 430 mm - height: 270 mm
<b>Mass:</b>	Kg. 19
<b>Noise level:</b>	sound pressure Lp(A) = 99,9 dB (brass keys) 100,2 dB (steel keys)



Note: in some working conditions, noise can exceed 90 dB (A). It is advisable to use suitable otoprotectors.

## 2.3 Electric circuit

La duplicatrice REKORD PRO è dotata di un motore che compie:

- 1350 rpm, consumes approximately 0.18 Kw, absorption 2A (230V-50Hz)
- 1620 rpm, consumes approximately 0.18 Kw, absorption 2A (230V-60Hz)

The main parts of the electric circuit on the REKORD PRO are listed below:

- 1) Main plug with fuses
- 2) Safety main switch
- 3) Motor on switch
- 4) Motor: 230V a.c. 50/60Hz
- 5) Condenser
- 6) Transformer
- 7) 5 led circuit board (lamp)

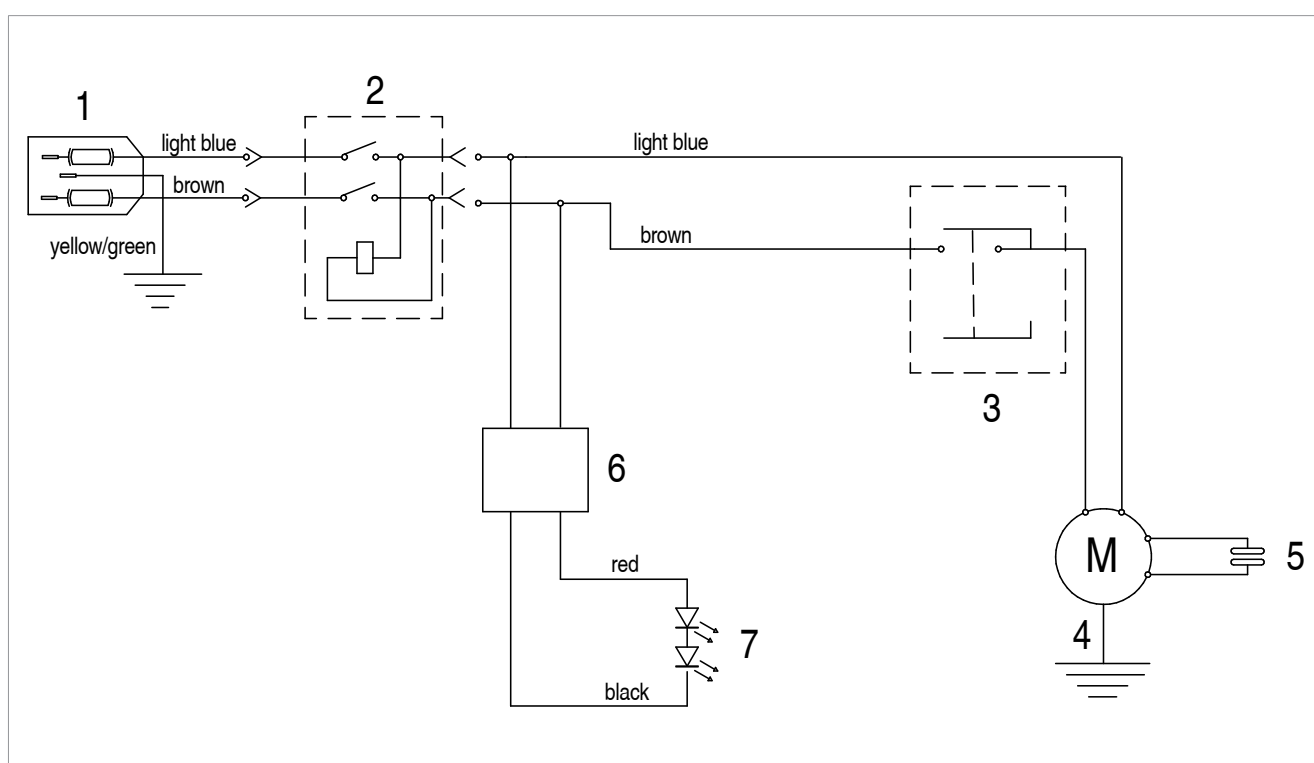

Fig. 7

## 2.4 Accessories provided

REKORD PRO comes with a set of accessories for its operation and maintenance (tools, hex wrenches, fuses) supplied in a special tool kit comprising.

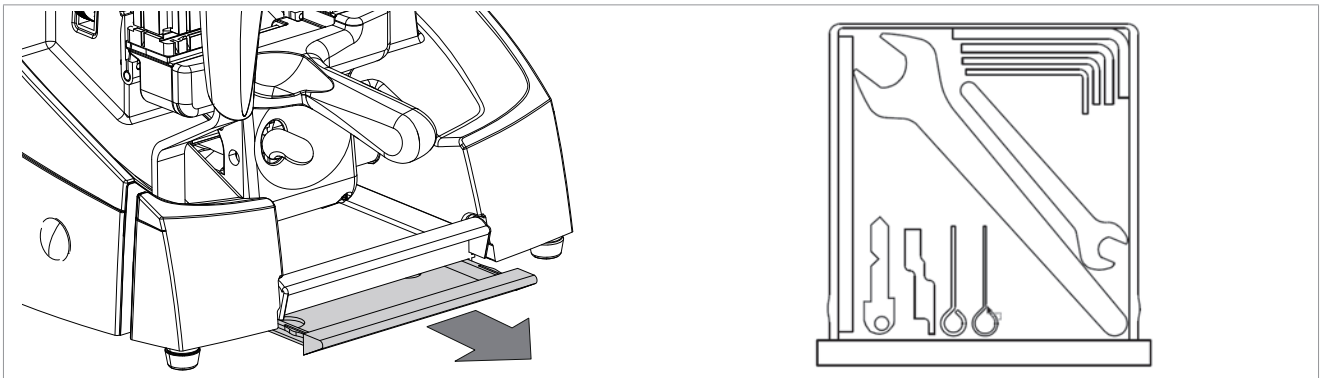
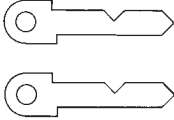

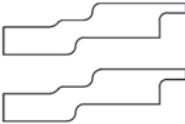

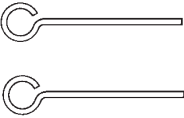

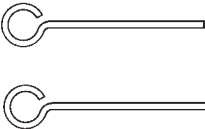
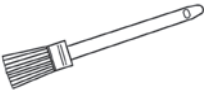
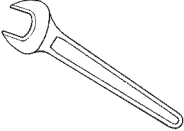



Fig. 8

adjusting keys (2 pcs) 	allen key 5 mm 
steel bars (2 pcs) 	1.5 mm/5 mm Allen key set 
steel pins Ø 1,20 mm 	cutter release rod 
steel pins Ø 1,70 mm 	cleaning brush 
spanner 19 mm 	fuse 250V 4 Amp rapid (F) 

### 3 TRANSPORT

The REKORD PRO key-cutting machine is easily transported and is not dangerous to handle. The packed machine can be carried by one person.

#### 3.1 Packing

The REKORD PRO is packed in a strong cardboard box, the dimensions of which are shown in Fig. 9 sufficiently robust to be used for storing the machine for long periods.

Inside the box the machine is enclosed in two expanded polymer shells. The shells and cardboard box ensure safe transportation and protect the machine and all its parts.

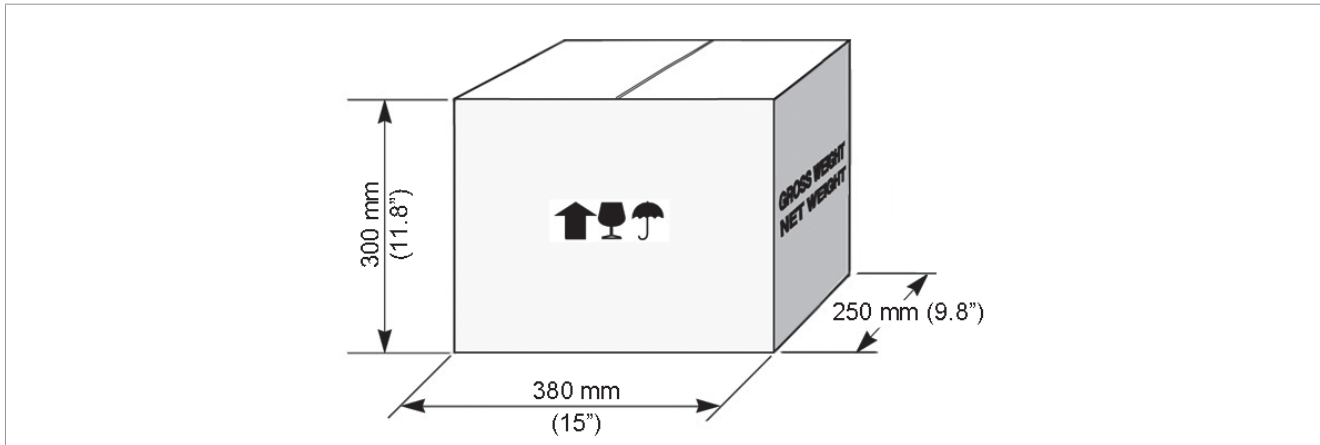

Fig. 9



Keep dry



Handle with care



This side up

**NOTE:** to avoid damaging the key-cutting machine it must always be transported in its packing case. This will prevent sudden movements or rough handling from damaging the machine, persons or things.

#### 3.2 Unpacking

To remove the machine from the packing box:

- 1) Cut the straps with scissors and remove.
- 2) Open the box without damaging it as it may be used again (e.g. removals, dispatch to the manufacturers for repairs or servicing).
- 3) Check the contents of the box, which should comprise:
  - 1 REKORD PRO key-cutting machine packed in a protective shell;
  - 1 set of documents, including: operating manual, spare parts list and guarantee;
  - 1 carriage lever handle;
  - 1 power cable;
  - 1 tool set;
- 4) Remove the key-cutting machine from the protective shell.

#### 3.3 Handling the machine

When the REKORD PRO has been unpacked, place it directly on its workbench.

This operation can be carried out by one person.



**ATTENTION:** firmly holding the base, and no other part, to lift and carry the machine.

## 4 MACHINE INSTALLATION AND PREPARATION

The REKORD PRO key-cutting machine can be installed by the purchaser and does not require any special skills. However, some checks and preparation for use need to be carried out by the operator.

### 4.1 Checking for damage

The REKORD PRO key-cutting machine is solid and compact and will not normally damage if transport, unpacking and installation have all been carried out according to the instructions in this manual. However, it is always advisable to check that the machine has not suffered any damage.

### 4.2 Environmental conditions

To ensure that the best use is made of the REKORD PRO key-cutting machine, certain parameters must be borne in mind: damp, badly ventilated sites should be avoided.

The ideal conditions for the machine are:

- temperature: between 10°C and 40°C;
- relative humidity: 60% circa;
- room illumination: approximately 500 Lux.

### 4.3 Positioning

- 1) Place the key-cutting machine on a horizontal surface, solid enough to take the weight (19 Kg).
  - to work with ease, we suggest that the workbench be approximately the height of the operator's hip.
  - it is important to leave clearance of at least 30 cm behind the machine and on each side to ensure proper ventilation (Fig. 10).
- 2) Ensure that the machines voltage is the same as that of the mains power supply, which must be properly earthed and provided with a differential switch.
- 3) Connect the power supply cable to the power supply socket (chap.4.4.2 and chap.4.5).

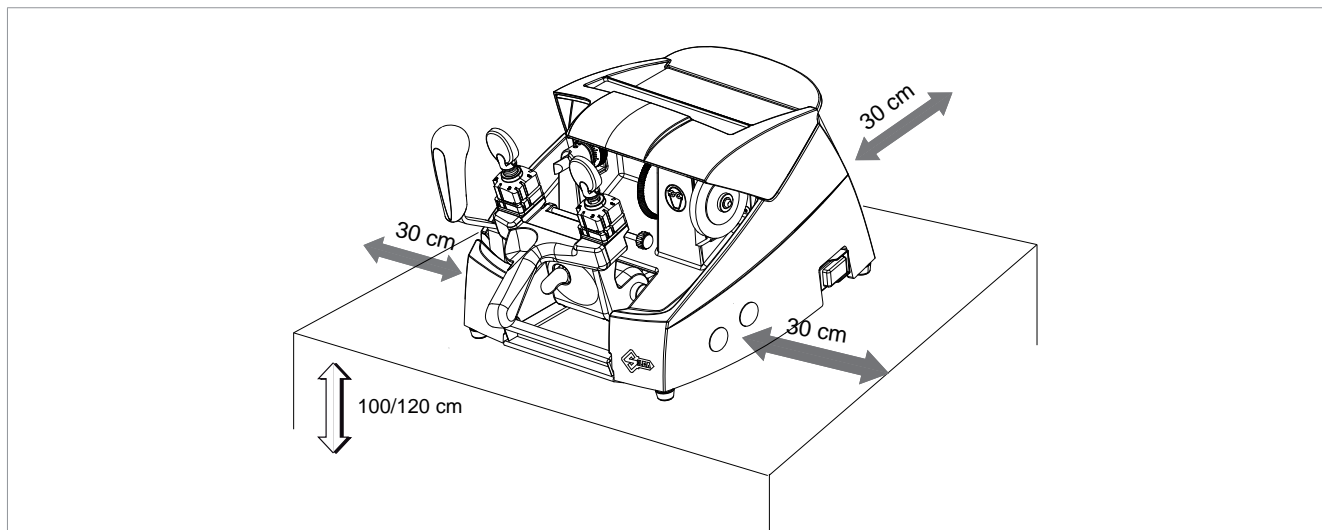

Fig. 10

## 4.4 Separate parts

The separately packed parts must be installed on the REKORD PRO key-cutting machine by the purchaser, as follows:

### 4.4.1 Carriage lever handle

Screw the handle onto the carriage (Fig. 11).

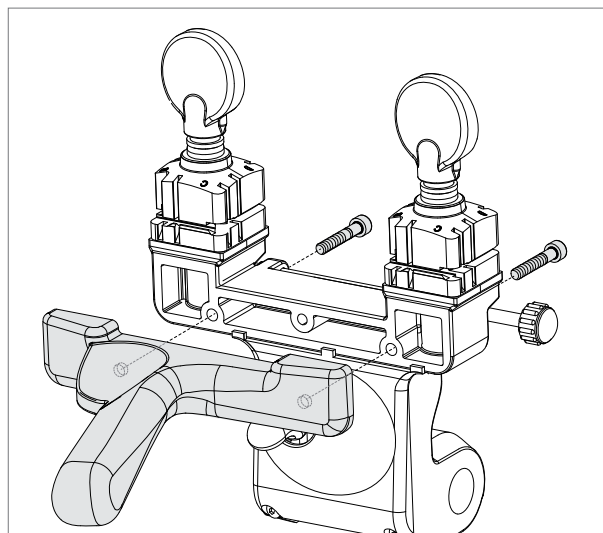

Fig. 11

### 4.4.2 Power cable

Connect the key-cutting machine power cable to the electricity mains.

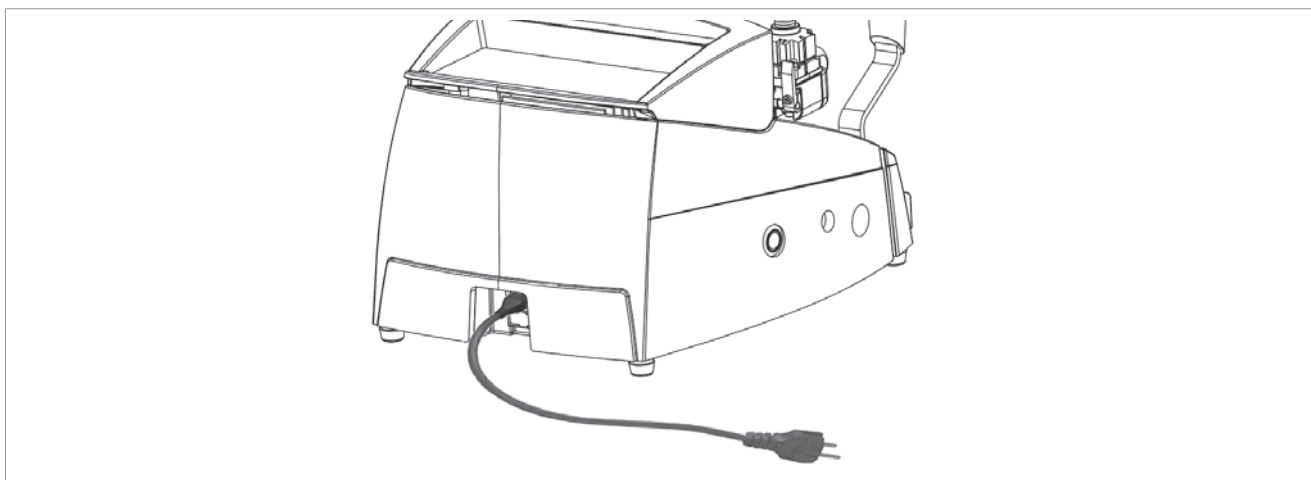

Fig. 12

## 4.5 Connection to the mains

For the safety of the operator and the machine it is important to ensure that the machine is connected to the proper mains voltage by means of an **earthed differential switch**.

## 4.6 Description of work station

The key-cutting machine needs only one operator, who has the following controls at his/her disposal (Fig. 13):

- main switch (O), located on the right-hand side of the machine; when activated the lamp (I) turns on.
- cutter motor start switch (N).
- carriage movement lever (D).
- carriage handle lever (A).
- carriage release lever (B).
- gauge knob (G).

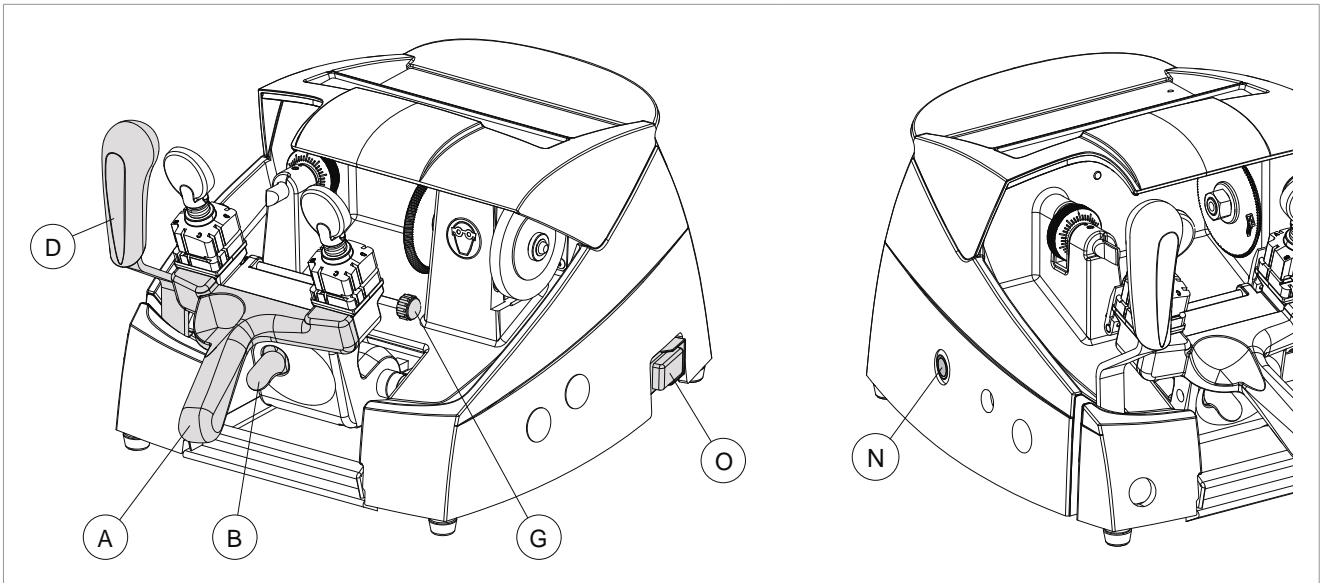

Fig. 13



## 5 MACHINE REGULATION AND UTILIZATION

### 5.1 Checking and calibration

The cutting tool on the machine is the part used to cut the key blanks and should be periodically checked and replaced, if necessary.

Every time the cutting tool is changed, and during periodical operational tests, check calibration.

### 5.2 Calibration

The REKORD PRO key-cutting machine requires two types of calibration: **axis** and **depth**.

#### Axis calibration:

Axis calibration is regulation of the space between cutting and the stop (Fig. 14 and Fig. 15).

The axis setting for the REKORD PRO is fixed and is established on assembly in our workshops.

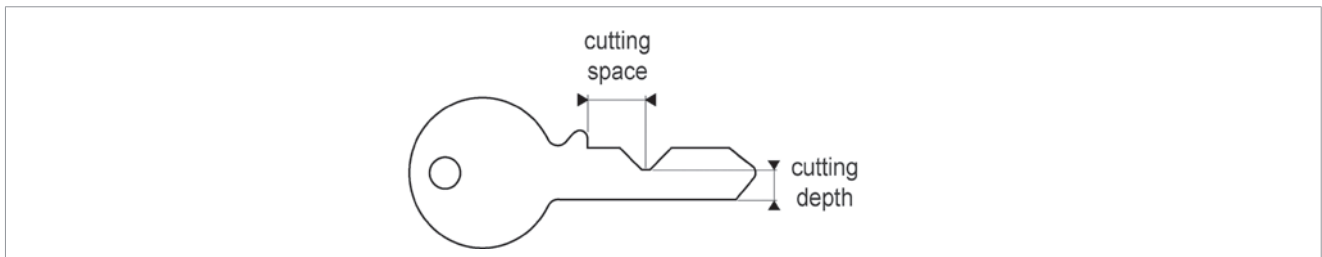

Fig. 14

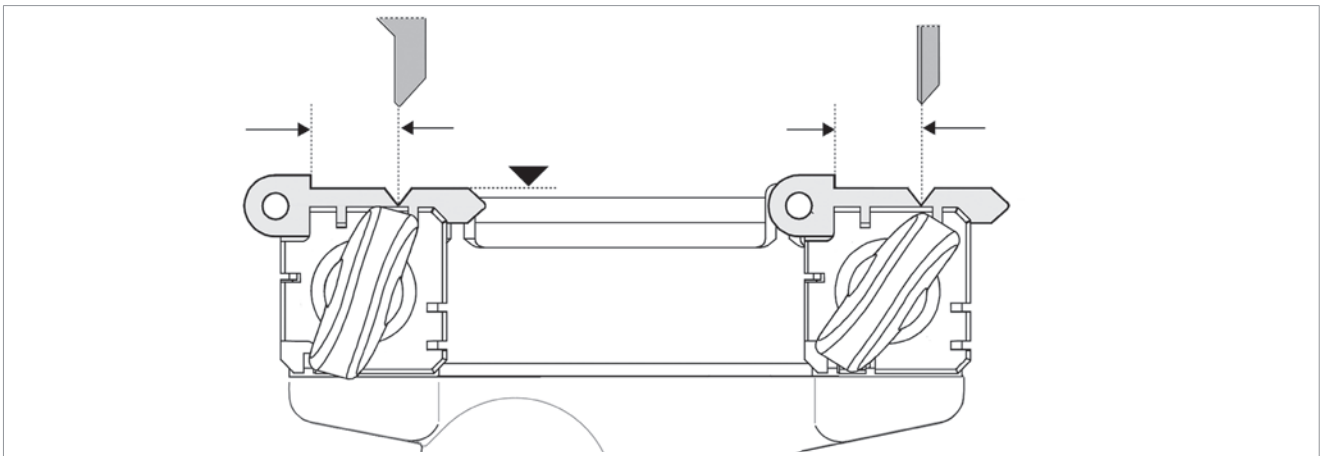

Fig. 15

**Depth calibration:**

Depth calibration is regulation of the cutting depth (Fig. 14). Proceed as follows:

- 1) **Ensure that the key-cutting machine is off by unplugging the power cable.**
- 2) Place the adjustment keys (provided) on the clamps (Fig. 16).
- 3) Check that the adjustment plates adhere properly to the clamps.
- 4) Turn the calibration rod towards the operator so that the gauges (H) into contact with the adjusting plates (Fig. 16).
- 5) Lower the gauge rod.

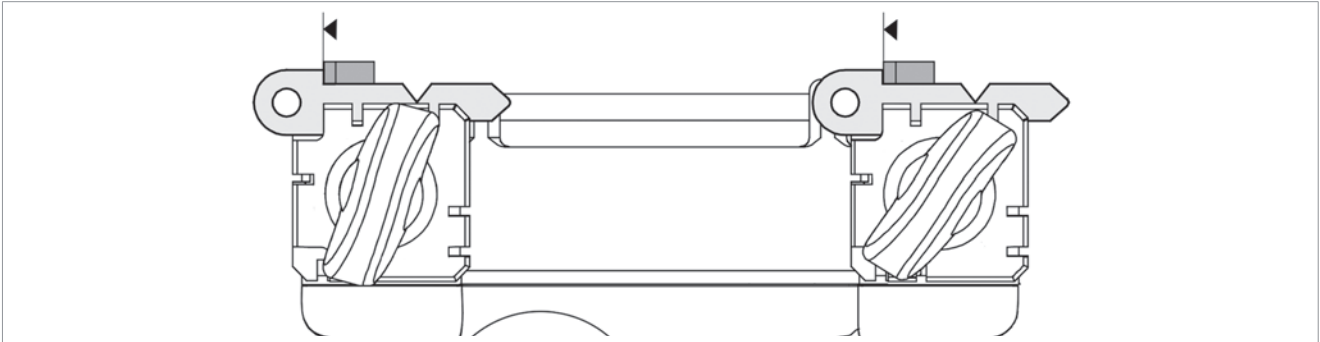

Fig. 16

- 6) Unlock the carriage with the lever (B) and move it towards the cutting tool.
- 7) Take the keys into contact with cutting tool and tracer point (Fig. 17).
- 8) Turn the cutting tool anticlockwise manually and check that it skims the adjusting keys in several places.
- 9) If necessary, regulate the depth of the cut with the micrometric tracer point, as follows:
  - a) loosen the screw (J1) holding the tracer point.
  - b) turn the ring nut (K) clockwise to advance the tracer point (shallower cuts) (Fig. 18).
  - c) turn the ring nut (K) anticlockwise to return (deeper cuts) (Fig. 19).

**NOTE: each notch on the centesimal ring corresponds to 0,025 mm (Fig. 17).**

- 10) Repeat these operations until regulation is complete, then tighten the tracer point locking grub screw (J1).

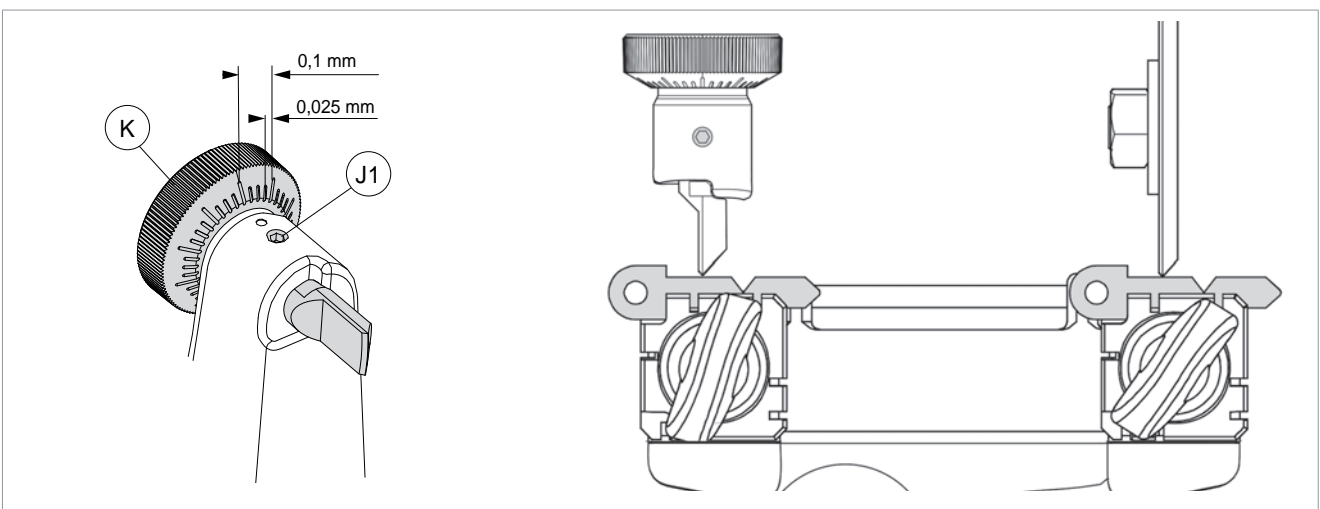

Fig. 17

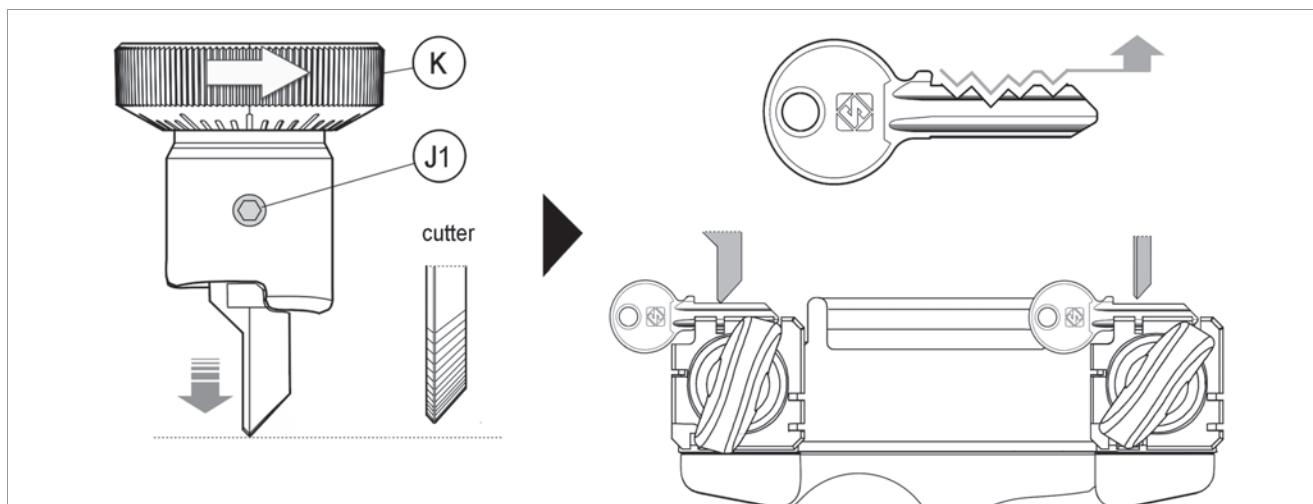

Fig. 18

- Turn the nut to the **RIGHT** (clockwise) to take the tracer point down. Result: **SHALLOWER CUTS**.

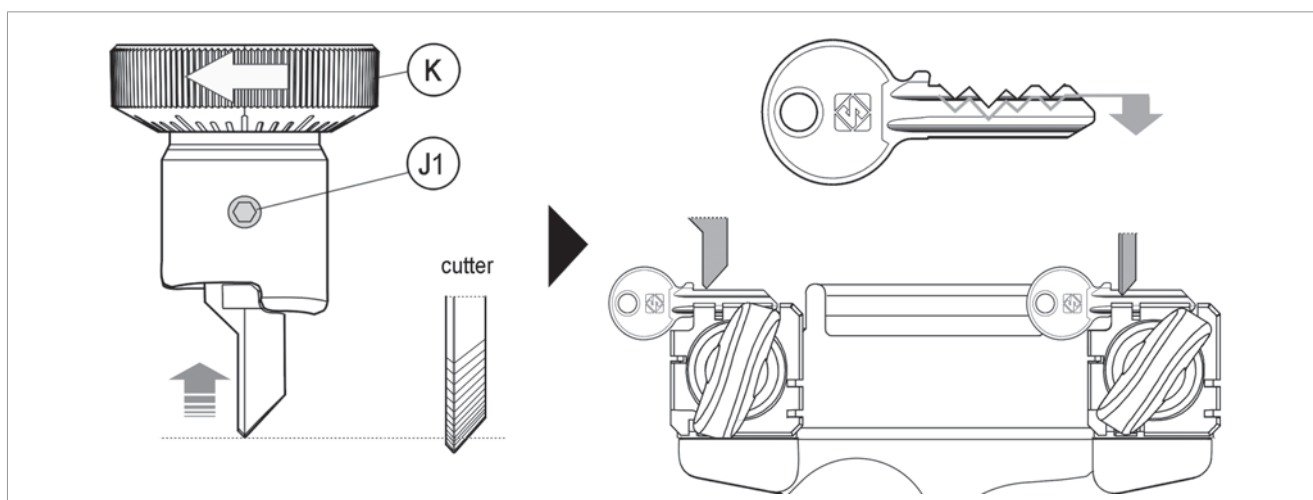



Fig. 19

- Turn the nut to the **LEFT** (anticlockwise) to take the tracer point up. Result: **DEEPER CUTS**.

## 6 CUTTING OPERATIONS



**ATTENTION:** for complete safety during the cutting operations, take the following precautions:

- Always work with dry hands.
- Check that the machine is properly earthed.
- Wear protective goggles even if the machine has a protective shield over the cutting tool.
-  Start the motor (switch N) only after completing the operations on the carriage (key insertion/removal..).
- Keep hands away from the cutting tool in motion.
- Before duplicating, remove the gauges.

### 6.1 Key cutting

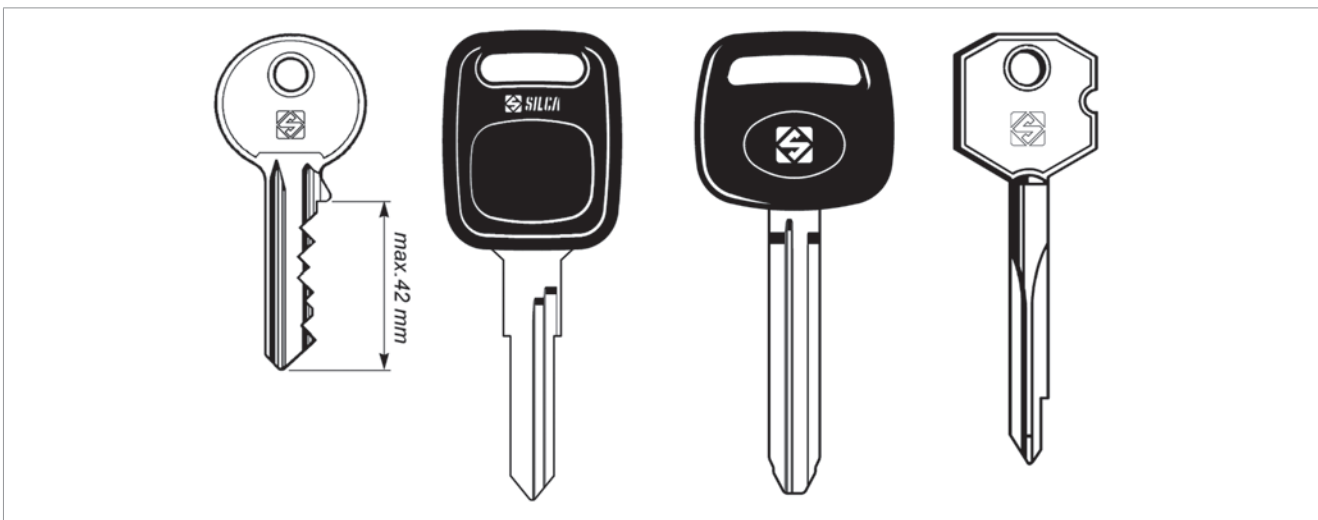

Fig. 20

Place the clamps on the required side (see chap.6.1.1):

- **Side A** of the clamp: for keys to be fitted on their backs, keys with double cuts without groove and cruciform keys (Fig. 21);
- **Side B** of the clamp: for keys placed on their backs and having cuts with a depth of less than 3,9 mm (Fig. 21);
- **Side C and D** of the clamp: for keys to be cut on both sides and locked on the groove (Fig. 21).

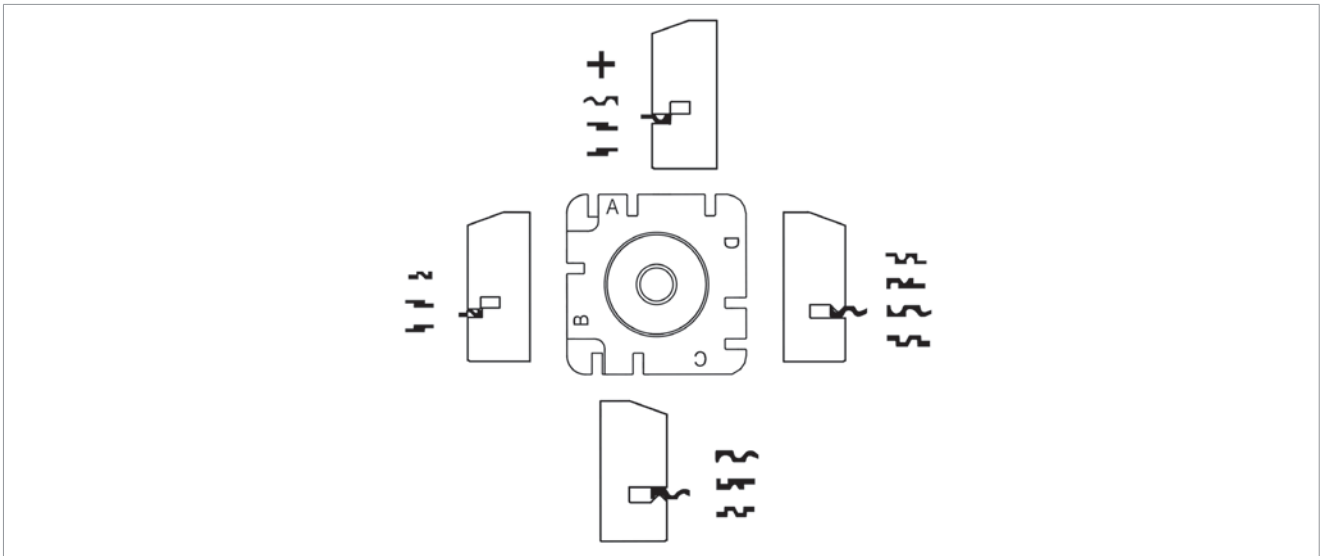

Fig. 21

### 6.1.1 Clamp rotation

Positioning the correct side to be used is quick and easy.

- 1) Loosen the clamp closing knob by a few turns.
- 2) Turn the clamp so that the required side is facing the tracer point and cutter.

**NOTE:** carry out the operation for both clamps.

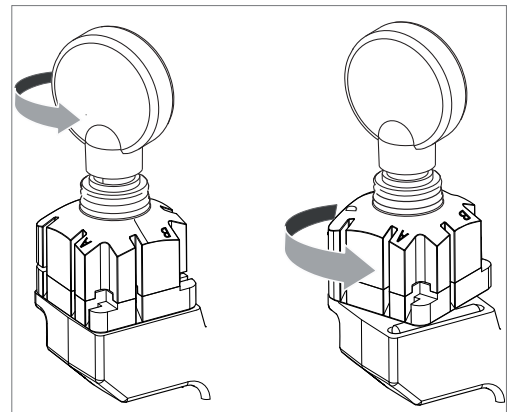

Fig. 22

### 6.1.2 Securing the keys in the clamps

- 1) Position the original key (left-hand jaw) and key blank (right-hand jaw), ensuring that:
  - a) the keys are well positioned and secured in the clamp;
  - b) the key stop is resting against the calibration tab (H);
- 2) Secure the keys by closing the clamps with the knobs (F).
- 3) Lower the gauge rod by turning knob (G).

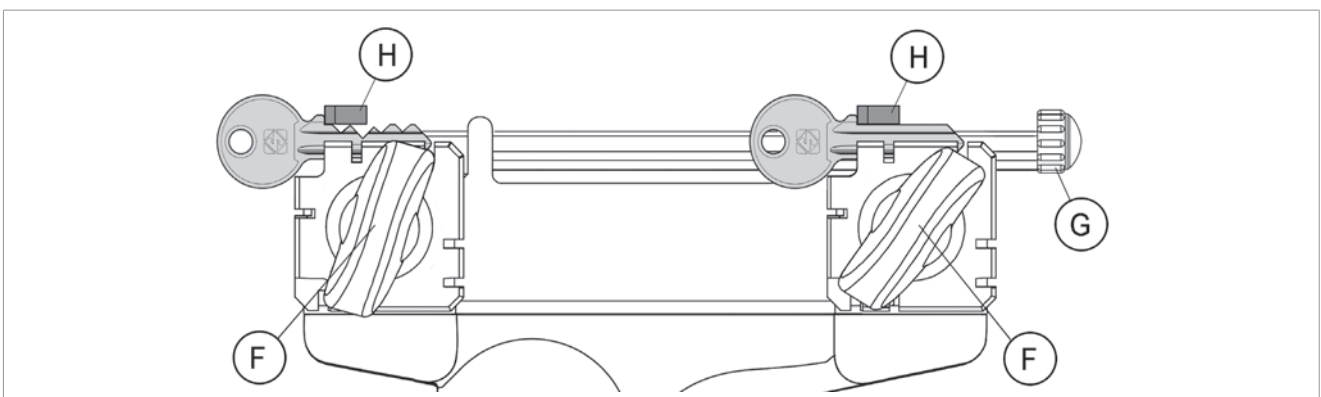

Fig. 23

### 6.1.3 Key cutting



**ATTENTION: make sure the gauges (H) have been lowered.**

Start the motor with the switch (N), the key-cutting machine is ready for cutting:

- 1) Unlock the carriage with lever (B), use handle (A) to bring the carriage towards tracer point/cutter and keep the tracer on the cuts starting from the key stop (Fig. 24).
- 2) To copy the key move the carriage sideways from right to left by means of the lever (D). In case of double cuts repeat the operation in the second side of the key.
- 3) Lower and lock the carriage.
- 4) Turn off the switch (N) before removing the duplicated key.
- 5) Remove the keys from the clamps.
- 6) Turn on the cutter motor with switch (N) and smooth off the key edges by means of the brush (P).

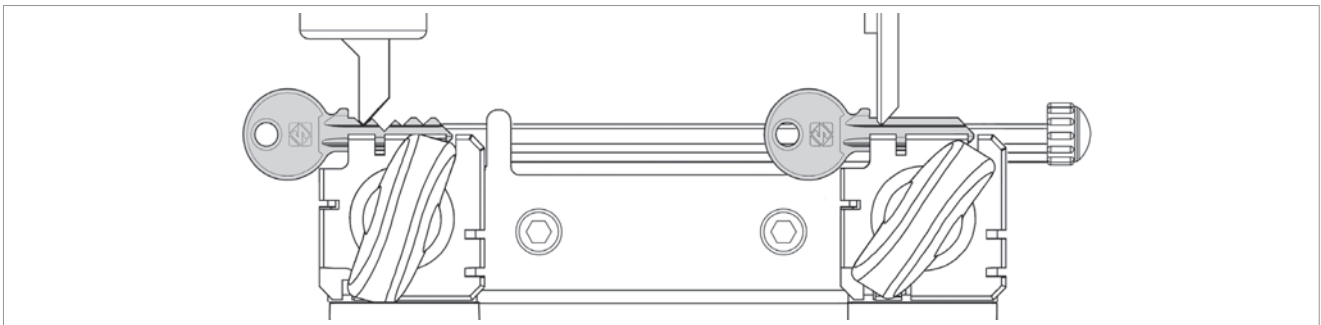

Fig. 24

### 6.2 Using the accessories

The accessories provided with machine to assist key-cutting are:

- pins
- bars

#### Using the pins

For keys with narrow stems the pins must be placed between the bottom of the clamp and the back of the key so that the key protrudes sufficiently out of the clamp and therefore can be properly read and cut (Fig. 25-B, Fig. 25-C). If the key has a narrow stem and is also very thin, 2 pins must be used (Fig. 25-B).

If the key thickness is too fine to guarantee a good grip in the clamps, a pin must be used (Fig. 25-A).



**ATTENTION: the pins provided have two different diameters: 1,20 mm and 1,70 mm; It is essential to use pins with the same diameters for locking both the original and the key blank.**

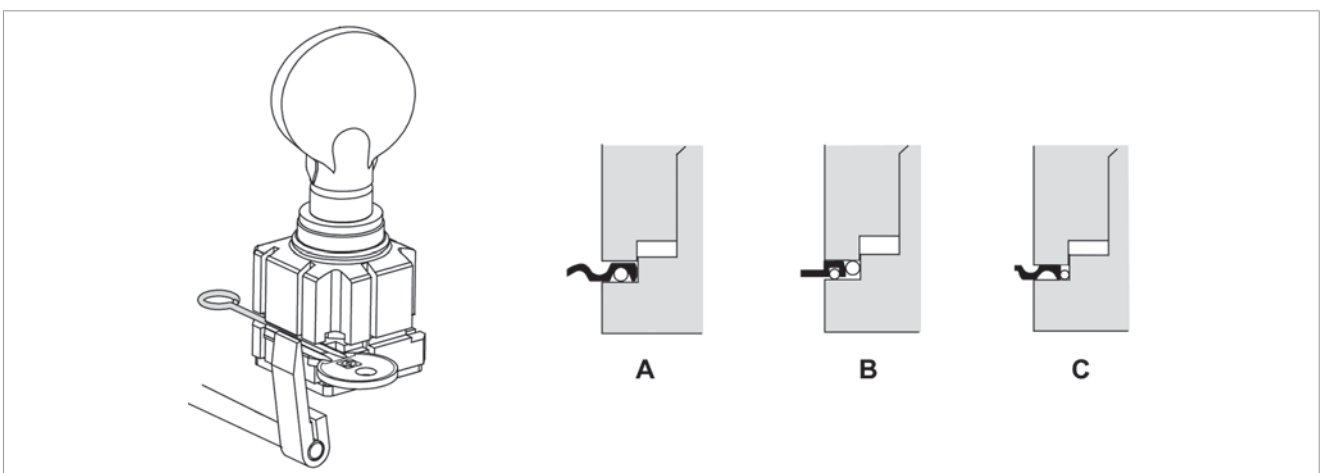

Fig. 25

## Using the bars

The bars provided are used for cutting cruciform keys (Fig. 26) and as a tip rest for locking keys with no stop (Fig. 27).

### Cutting cruciform keys using bars

The cruciform keys (90°) can be cut with the REKORD PRO clamps and the aid of the bars.

#### Positioning cruciform keys:

- 1) Leave the gauges (H) in the idle position.
- 2) Insert the bars into the slot in the clamps.
- 3) Butt the key stop against the bars.
- 4) Secure the keys in the clamps.
- 5) Remember to remove the bars before proceeding with cutting.**
- 6) Cut the first side.
- 7) Repeat the operation, turning both keys in the same direction for the other positions.

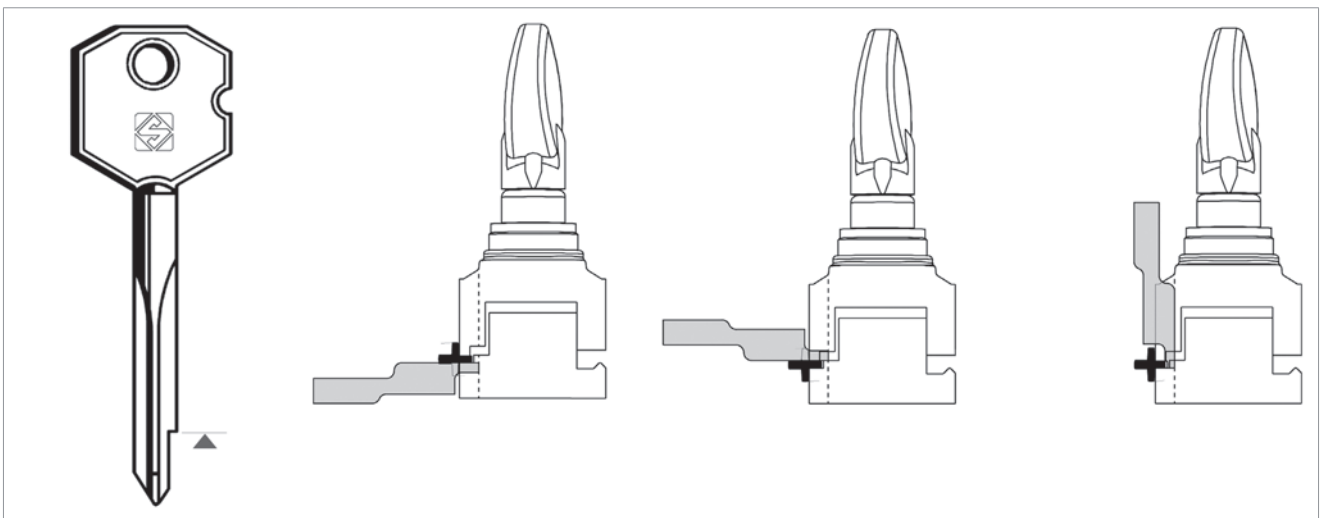

Fig. 26

### Tip stop with a bar

The bars can be used with keys which have no stop. Proceed as follows:

- 1) Leave the gauges (H) in the idle position.
- 2) Insert the bars into the slot in the clamps.
- 3) Rest the tip of the key against the bar.
- 4) Secure the key and remove the bar.

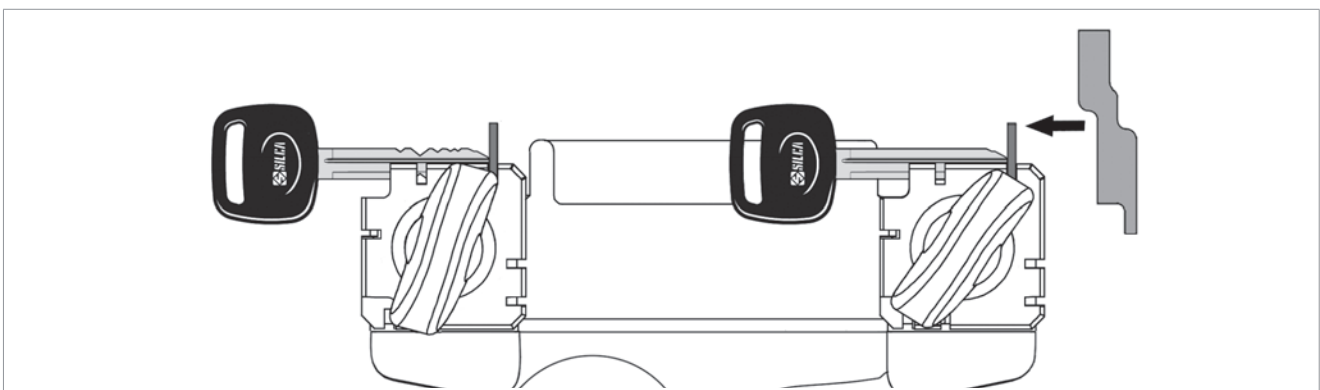

Fig. 27

## 7 MAINTENANCE

**⚠ ATTENTION:** for repairs or replacement of parts for maintenance, the 'CE' mark is guaranteed only if original spare parts provided by the manufacturer are used.

Although the key-cutting machine does not require special maintenance, it is advisable to check and, if necessary, replace the parts subject to wear, such as: the belt, cutting tool, brush, tracer point.

**Maintenance operations must be carried out only by authorised technicians or in the After-Sales Service Centres recommended by Silca.**

**CLEANING:** keep the carriage and clamps free of chippings from the cutting operations by cleaning with a dry brush.

**⚠ ATTENTION:** do not use compressed air!

**⚠ ATTENTION:** to keep the machine well maintained we recommend using protective oil, e.g. WD40 or similar, applied to the burnished mechanical parts. This prevents oxidation of the parts in question (clamps, guides, carriages...).

Before starting any type of maintenance (checks or replacements), read the instructions below:

- Never carry out maintenance or servicing with the machine switched on.
- Always remove the mains plug.
- During maintenance operations, the operator must always be able to check that the power cable plug is disconnected.
- Follow all the instructions in the manual to the letter.
- Use original spare parts.
- Always check that any screws or nuts removed when replacing a piece are properly tightened.

### 7.1 Replacing the brush

When the brush no longer cleans off the burrs it must be replaced as follows:

**⚠ ATTENTION:** remove the mains plug.

- 1) Slot the locking rod (provided) into the hole of the cutting tool shaft (Fig. 28).
- 2) Use the Allen wrench to loosen the screw (P1) holding the brush (P) in place (Fig. 28).
- 3) Replace the brush and tighten the screw (P1) with the Allen key.
- 4) Remove the locking rod from the cutting tool shaft.

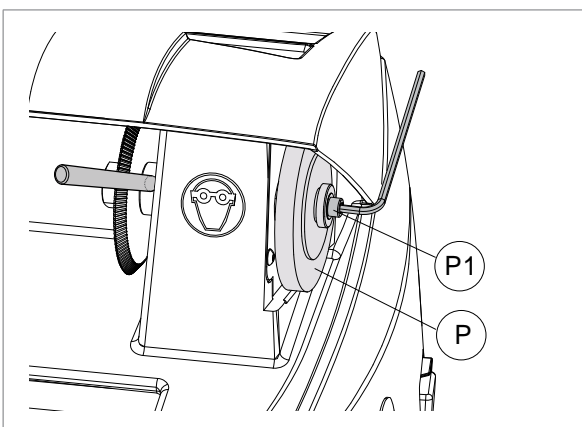

Fig. 28

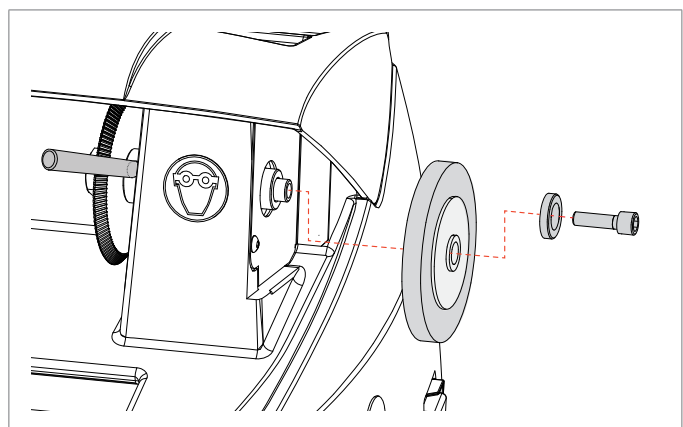



Fig. 29



## 7.2 Replacing the cutting tool

To replace a worn cutting tool, proceed as follows:

 **ATTENTION: remove the mains plug.**

- 1) Slot the locking rod (provided) into the hole of the cutting tool shaft (Fig. 30).
- 2) Use the spanner provided to loosen the cutting tool locking nut (L1) (Fig. 31).

 **ATTENTION: the thread is left-handed.**

- 1) Remove the worn cutting tool.
- 2) Carefully clean the new cutting tool and its seat.
- 3) Install the new cutting tool (pay attention to the rotation direction) and tighten the nut (L1) anticlockwise.
- 4) Remove the locking rod.
- 5) Check calibration (chap.5.2).

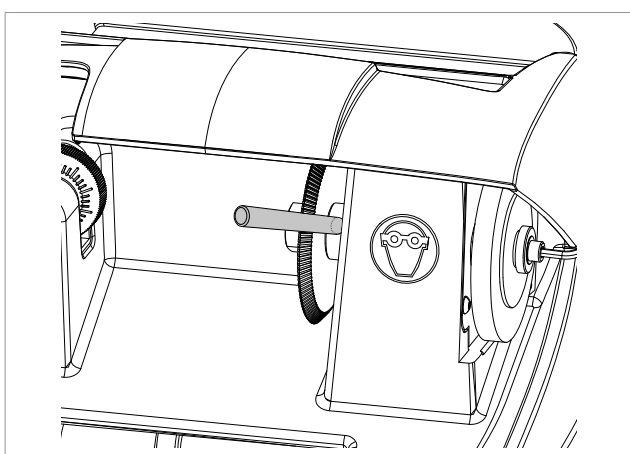

Fig. 30

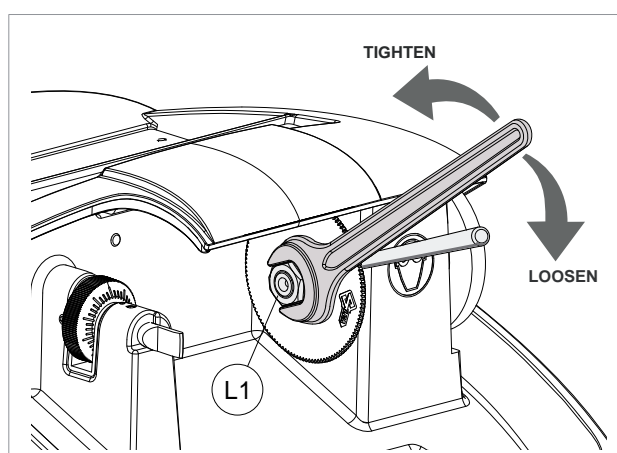



Fig. 31

### 7.3 Replacing the tracer point

 **ATTENTION:** remove the mains plug.

- 1) Remove the two pads (Fig. 32).
- 2) Loosen the 3 screws (M1) and remove the top cover (M) (Fig. 32 and Fig. 33).
- 3) Loosen the screw (K1) (Fig. 34).
- 4) Loosen the grub screw (J1).
- 5) Loosen the tracer point by turning it anticlockwise until is fully released.
- 6) Fit the new tracer point and screw down to the end of run.
- 7) Tighten the grub screw (J1).
- 8) Tighten the screw (K1).
- 9) Re-set the machine as described in chap.5.2.

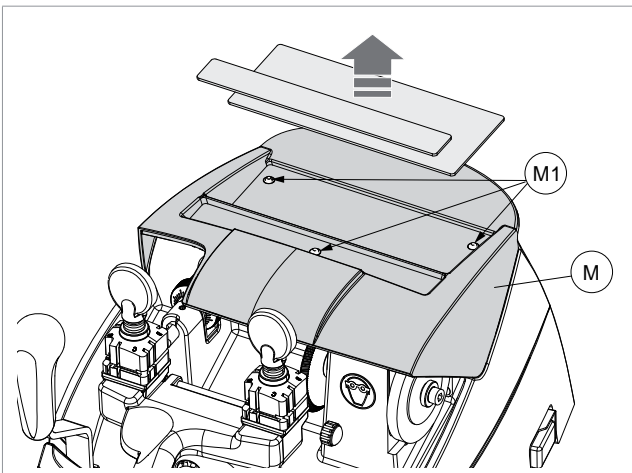

Fig. 32

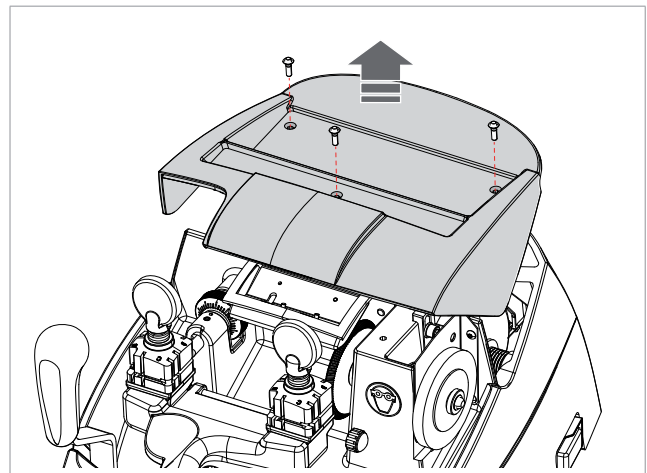

Fig. 33

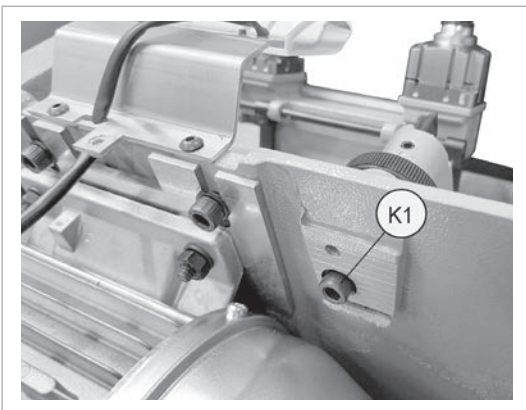

Fig. 34

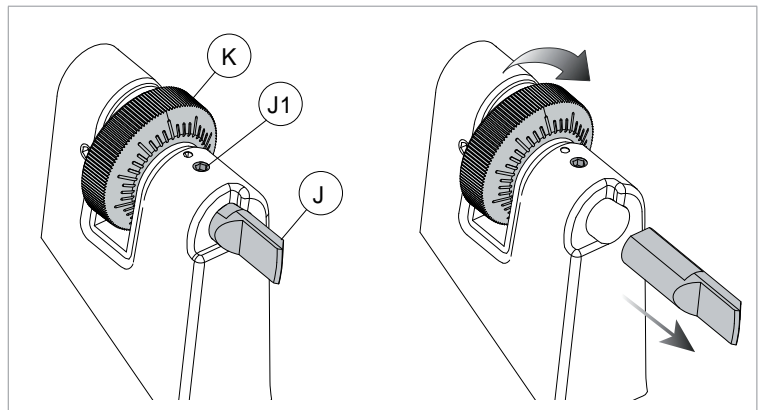



Fig. 35

## 7.4 Access to the lower compartment

 **ATTENTION:** remove the mains plug.

- 1) Detach the wire from the key-cutting machine socket.
- 2) Remove the double box (tool holder/swarf tray) (Fig. 36).
- 3) Turn the machine over onto its back.
- 4) Loosen the 6 screws to remove the bottom plate (Fig. 37).

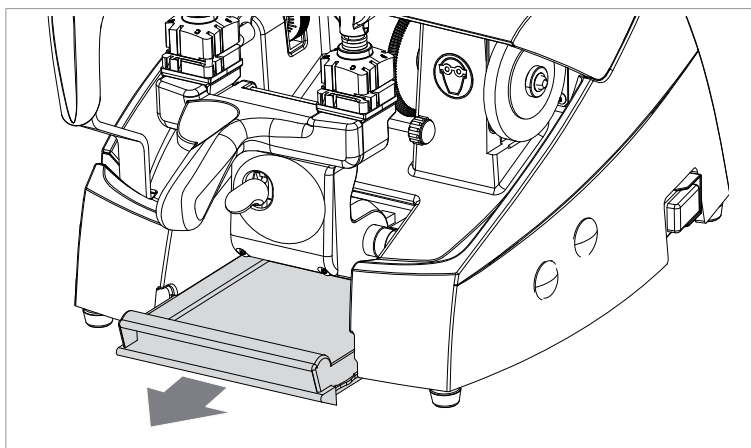

Fig. 36

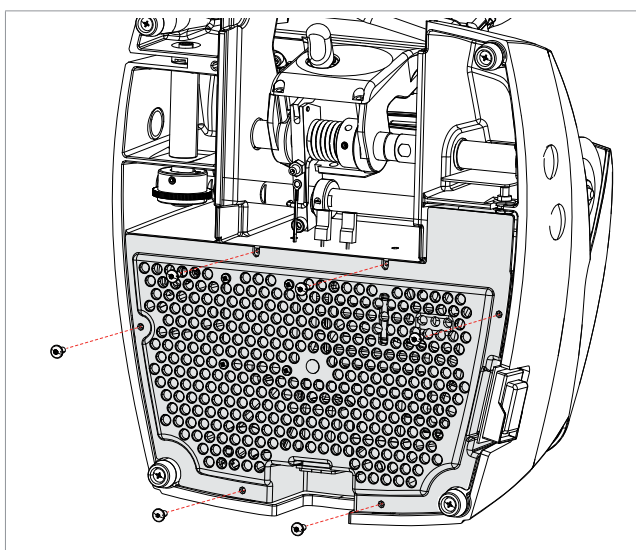

Fig. 37

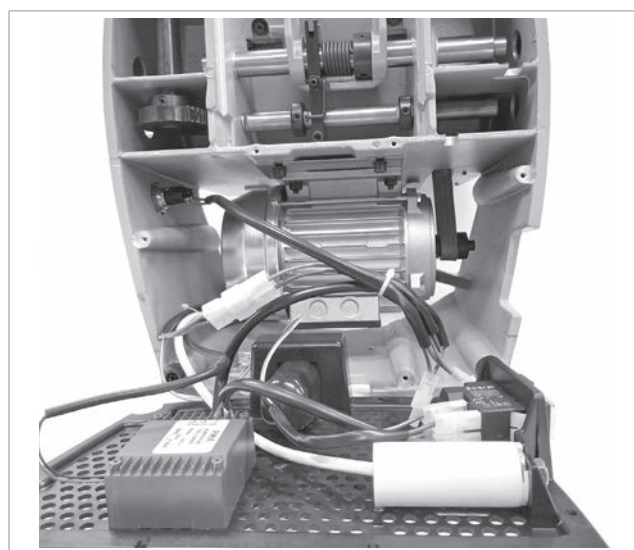



Fig. 38

## 7.5 Replacing lamp feed (transformer)

 **ATTENTION:** remove the mains plug.

- 1) Access the lower compartment (chap.7.4).
- 2) Loosen the 2 low voltage connector screws (Q1) remove and place in their seat on the new transformer, securing with the 2 screws (Fig. 39).
- 3) Loosen the 2 mains connector screws (Q3) remove and place in their seat on the new transformer, securing with the 2 screws.
- 4) Loosen the screws (Q2) fixing the transformer to the bottom plate and remove (Fig. 40).
- 5) Place the new transformer in position and secure with the screws (Q2).
- 6) Replace the bottom plate and secure with the 6 screws (Fig. 37).
- 7) Return the machine to its upright position.

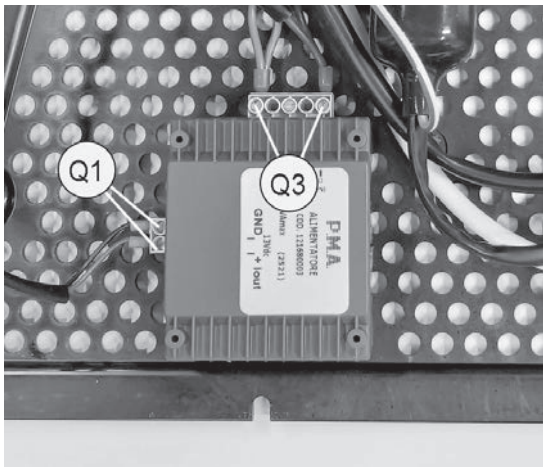

Fig. 39

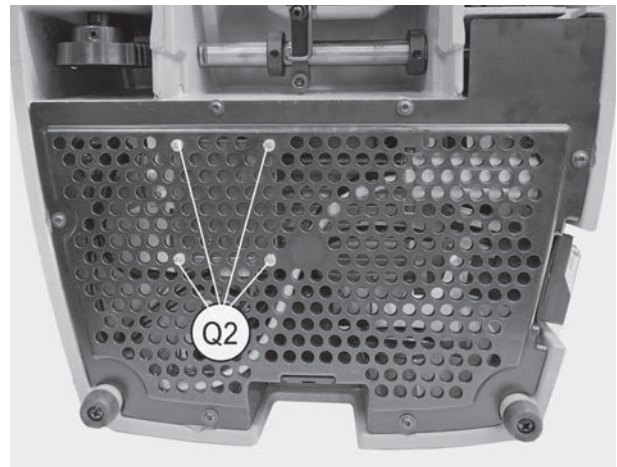

Fig. 40

## 7.6 Replacing lamp set/lamp protection

### • Lamp set



**ATTENTION: remove the mains plug.**

- 1) Remove the two pads (Fig. 41)).
- 2) Loosen the 3 screws (M1) and remove the top cover (M) (Fig. 32).
- 3) Access the lower compartment (chap.7.4).
- 4) Loosen the 2 low voltage connector screws (Q1) and remove them (Fig. 39).
- 5) Position the machine upright again.
- 6) Loosen the 2 lamp fixing screws (L1) and remove (Fig. 41).
- 7) Replace the top cover and secure with the 3 screws (M1).
- 8) Turn the machine over onto its back.
- 9) Connect the 2 connectors in the low voltage supply outlet seat and secure with the 2 screws (Q1) (Fig. 39).
- 10) Replace the bottom plate and secure with the 6 screws (Fig. 37).
- 11) Return the machine to its upright position.

### • Lamp protection



**ATTENTION: remove the mains plug.**

- 1) Remove the two pads (Fig. 32).
- 2) Loosen the 3 screws (M1) and remove the top cover (M) (Fig. 32).
- 3) Loosen the 2 lamp fixing screws (L1) and remove (Fig. 41).
- 4) Loosen the 2 screws (L2) in order to remove the lamp protection (L3) (Fig. 42).
- 5) Fit the new protection and secure with the 2 screws (L2).
- 6) Replace the lamp unit and secure with the 2 screws (L1) making sure the wiring is positioned to-wards the bottom of the machine.
- 7) Replace the top cover and secure with the 3 screws (M1).

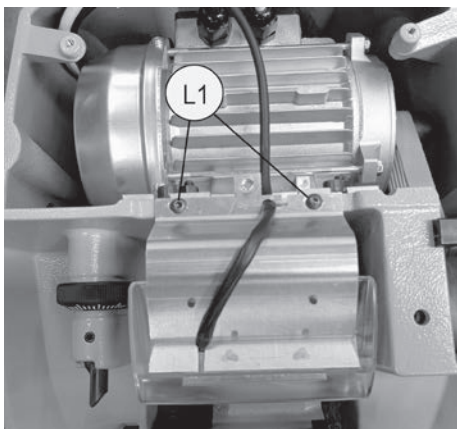

Fig. 41

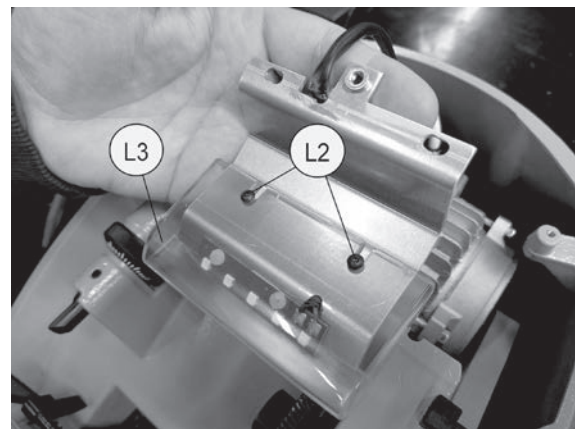

Fig. 42

## 7.7 Replacing the fuses

**!** **ATTENTION:** disconnect the power lead from the mains and machine.

- 1) Remove the fuses box (U) from the key-cutting machine socket (Fig. 43).
- 2) Replace the fuses (U1).
- 3) Close the fuses box and connect the power cable.

**!** **ATTENTION:** fuses must always be replaced with others of the same type and with the same Amps (250V 4 Amp rapid F).

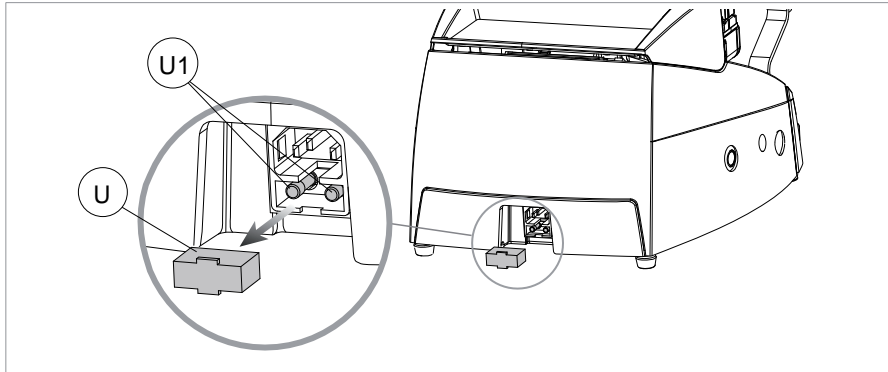

Fig. 43

## 7.8 Regulating carriage depth

The carriage on the REKORD PRO can be regulated to protect the clamps from coming into contact with the tracer point or cutting tool.

**IMPORTANT:** the play between cutting tool/tracer point and clamps must be 0.1 mm.

Should it be different from this, proceed as follows:

**!** **ATTENTION:** remove the mains plug.

- 1) Release the carriage, raise against the cutting tool and take to the end of its run (Fig. 44).
- 2) Remove the double box (tool holder/swarf tray) (Fig. 36).
- 3) Release the nut with the spanner (Fig. 44)
- 4) Use the Allen wrench to screw or unscrew the grub screw in order to move the carriage away from or towards the tracer point and cutting tool.
- 5) Tighten the nut.

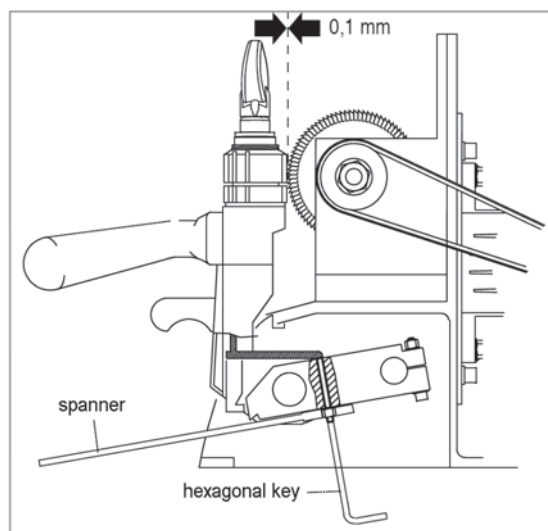

Fig. 44

## 7.9 Replacing the main switch

**!** **ATTENTION:** remove the mains plug.

- 1) Access the lower compartment (chap.7.4).
- 2) Detach the 4 connectors (Y1) paying special attention to their position (Fig. 45).
- 3) Remove the switch (O) making pressure on the tabs with a screwdriver (Fig. 46).
- 4) Fit the new main switch.
- 5) Reconnect the 4 connectors (Y1).
- 6) Replace the bottom plate and secure with the 6 screws (Fig. 37).
- 7) Return the machine to its upright position.

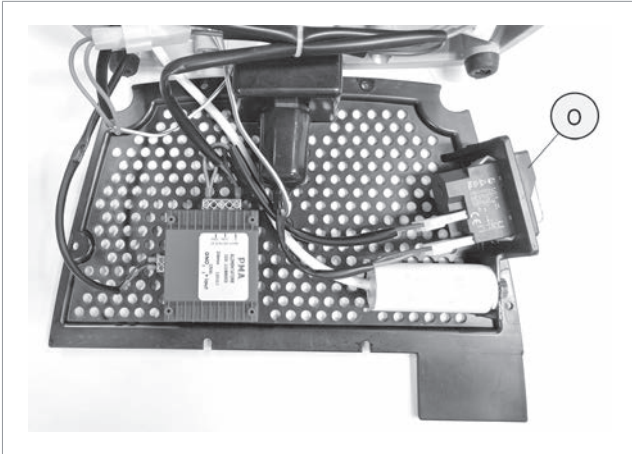

Fig. 45



Fig. 46

## 7.10 Replacing motor on switch

**!** **ATTENTION:** remove the mains plug.

- 1) Access the lower compartment (chap.7.4).
- 2) Detach the connectors (S2) paying special attention to their position.
- 3) Fully unscrew the ring nut (S3) and remove the switch.
- 4) Insert the new switch and tighten the ring nut (S3).
- 5) Reconnect the 2 connectors (S2).
- 6) Replace the bottom plate and secure with the 6 screws (Fig. 37).
- 7) Return the machine to its upright position.

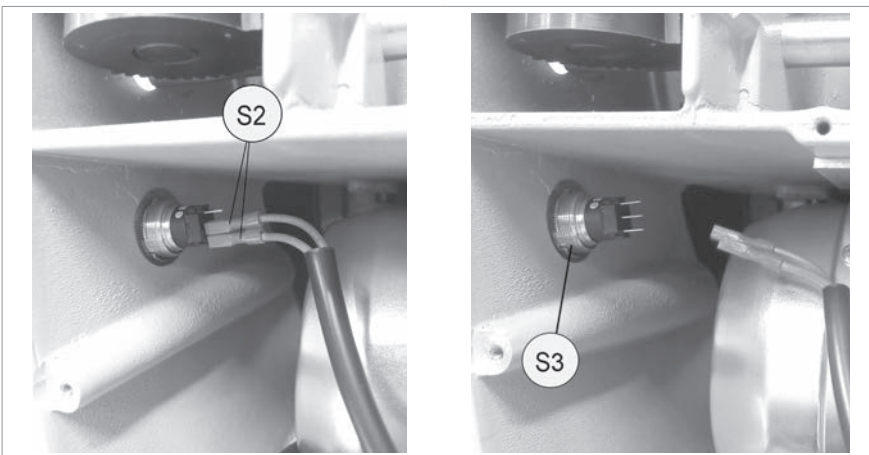

Fig. 47



Fig. 48

## 7.11 Replacing and/or tightening the belt

Worn or loose belts (T) must be replaced or adjusted so as to ensure safe and proper operation of the cutting tool/brush.

- **Tension:**



**ATTENTION: remove the mains plug.**

- 1) Remove the two pads (Fig. 49).
- 2) Loosen the 3 screws (M1) and remove the top cover (M) (Fig. 50).
- 3) Push the belt tightener (P1) downwards to tighten the belt.
- 4) Secure the belt tightener with the screw (P2).

- **Replacement:**



**ATTENTION: remove the mains plug.**

- 1) Remove the two pads (Fig. 49).
- 2) Loosen the 3 screws (M1) and remove the top cover (M) (Fig. 50).
- 3) Remove the brush (chap.7.1).
- 4) Remove the 3 screw (M2) to remove the protective cover (Fig. 51).
- 5) Loosen the screw (P2) and remove the belt tightener (P1) (Fig. 52).
- 6) Loosen the 4 screws (S1) of the plate motor (Fig. 53).
- 7) Raise the motor and remove the worn belt (Fig. 54).
- 8) Fit the new belt.
- 9) Tighten the 4 screws (S1).
- 10) Fit the belt tightener (P1) and push it downwards to tighten the belt.
- 11) Secure the belt tightener with the screw (P2).
- 12) Replace the protective cover and secure it with the 3 screws (M2).
- 13) Replace the brush.
- 14) Replace the top cover and secure with the 3 screws (M1).

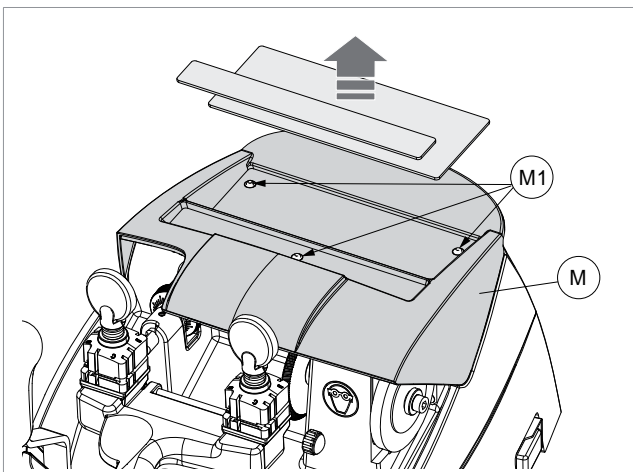

Fig. 49

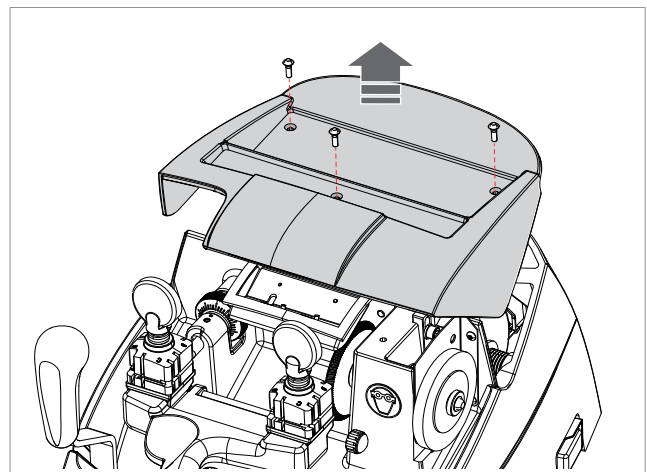

Fig. 50



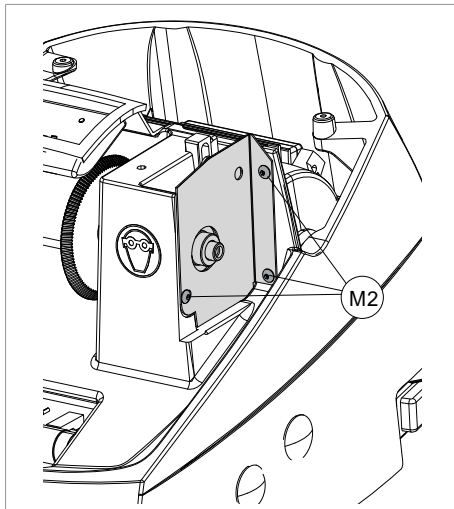

Fig. 51

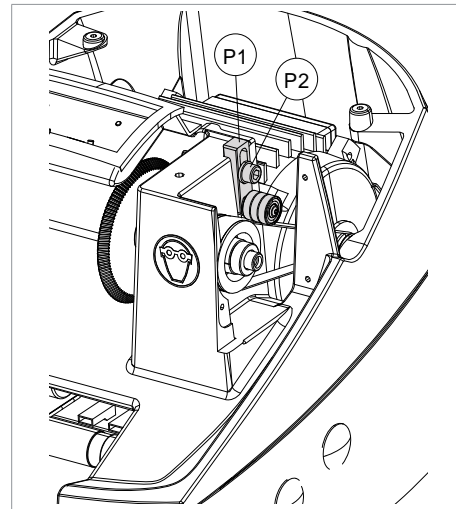

Fig. 52

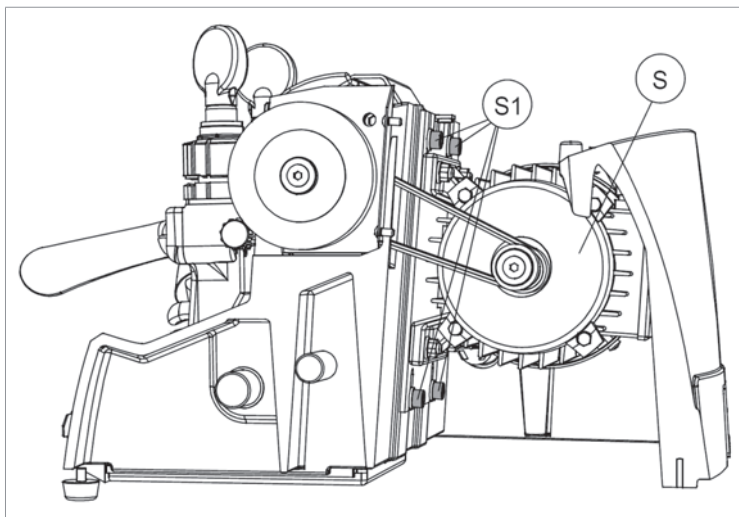

Fig. 53

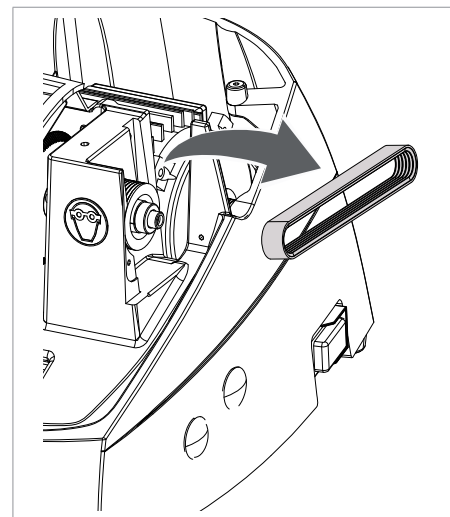



Fig. 54

## 7.12 Replacing motor/condenser

 **ATTENTION:** remove the mains plug.

### 7.12.1 Replacing motor

- 1) Remove the two pads (Fig. 49).
- 2) Loosen the 3 screws (M1) and remove the top cover (M) (Fig. 50).
- 3) Access the lower compartment (chap.7.4)
- 4) Detach the connectors (S2) from the motor on switch (Fig. 47).
- 5) Return the machine to its upright position.
- 6) Loosen the screw (P2) and remove the belt tightener (P1) (Fig. 52).
- 7) Loosen the 4 screws (S1) (Fig. 53) on the motor fixing plate and remove the belt.
- 8) Turn the machine over onto its back.
- 9) Loosen completely only the 2 lower screws (S1) the motor fixing plate and pull downwards (Fig. 56).

### 7.12.2 Replacing condenser

 **ATTENTION:** remove the mains plug.

- Access the lower compartment (chap.7.4)
- Remove the motor (chap.7.12.1)
- Loosen the nut (Z) (Fig. 58) and remove together with the washer.
- Loosen the 4 screws (S4) (Fig. 59) on the motor box and remove.
- Loosen the 2 condenser connection screws (X1) (Fig. 59).
- Loosen the nut on the wire grommet (X) and remove the condenser.
- Fit the new condenser, taking the wire through the nut (X) replace the motor box and secure with the 2 screws (X1).
- Tighten the grommet nut (X), replace the motor box and secure with the 4 screws (S4).
- Replace the condenser (see points 15 to 19).
- Loosen the 4 screws (S3) on the motor fixing plate (Fig. 57).
- Secure the new motor on the fixing plate with the screw (S3).
- Replace the motor.

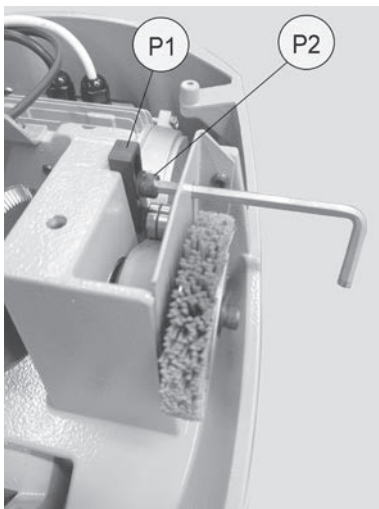

Fig. 55

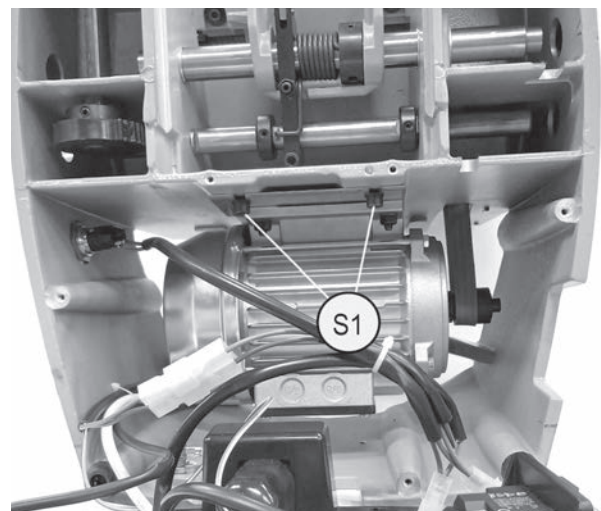

Fig. 56

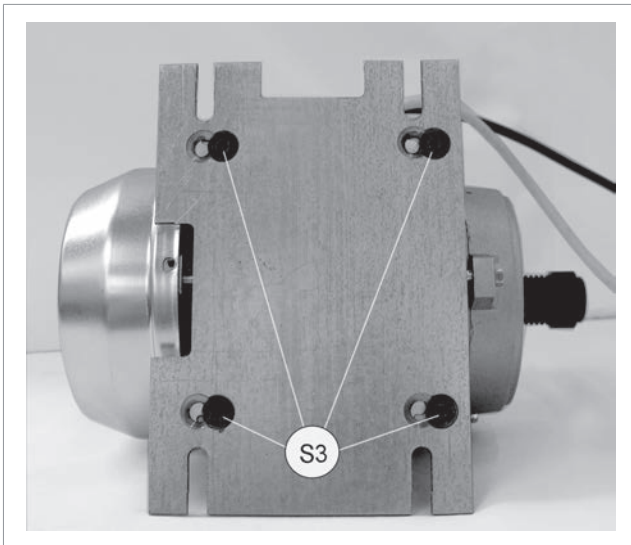

Fig. 57

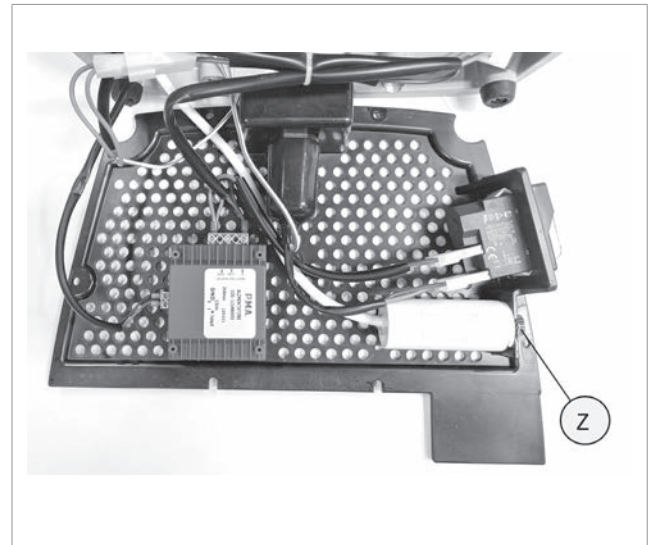

Fig. 58

- 10) Return the machine to its upright position.
- 11) Install the belt and tighten the 4 screws (S1) (Fig. 53) of the plate motor.
- 12) Push the belt tightener (P1) downwards to tighten the belt and secure it with the screw (P2).
- 13) Turn the machine over onto its back.
- 14) Connect the connectors (S2) (Fig. 47) to the motor on switch and fit the earth wire to its screw with the nut (S5) (Fig. 60).
- 15) Replace the condenser and secure with washer and nut.
- 16) Replace the bottom plate and secure with the 6 screws (Fig. 37).
- 17) Return the machine to its upright position.
- 18) Replace the top cover and secure with the 3 screws (M1) (Fig. 49).
- 19) Replace the pads.

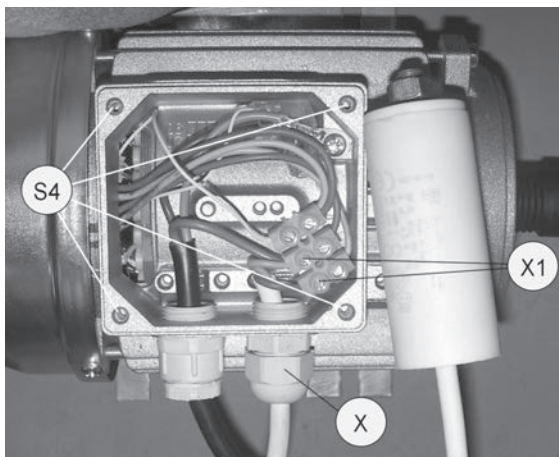

Fig. 59

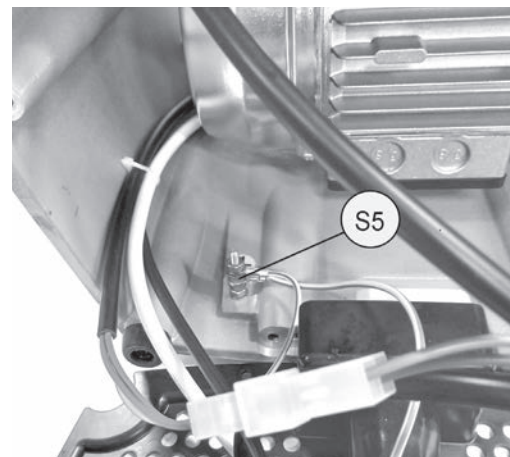

Fig. 60

## 8 DISPOSAL

For correct disposal please refer to current standards.

### INFORMATION FOR USERS OF PROFESSIONAL EQUIPMENT



#### ***From “Actuation of Directive 2012/19/EU regarding Waste Electrical and Electronic Equipment (WEEE)”***

The symbol of a crossed waste bin found on equipment or its packing indicates that at the end of the product's useful life it must be collected separately from other waste so that it can be properly treated and recycled.

In particular, separate collection of this professional equipment when no longer in use is organised and managed:

- a) directly by the user when the equipment was placed on the market before 31 December 2010 and the user personally decides to eliminate it without replacing it with new equivalent equipment designed for the same use;
- b) by the manufacturer, that is to say the subject which was the first to introduce and market new equipment that replaces previous equipment, when the user decides to eliminate equipment placed on the market before 31 December 2010 at the end of its useful life and replace it with an equivalent product designed for the same use. In this latter case the user may ask the manufacturer to collect the existing equipment;
- c) by the manufacturer, that is to say the subject which was the first to introduce and market new equipment that replaces previous equipment, if it was placed on the market after 31 December 2010;

Suitable separate collection for the purpose of forwarding discarded equipment for recycling, treatment or disposal in an environmentally friendly way helps to avoid possible negative effects on the environment and human health and encourages re-use and/or recycling of the materials making up the equipment.

The sanctions currently provided for by law shall apply to users who dispose of products in unauthorised ways.

## **9 ASSISTANCE**

Silca provides full assistance to purchasers of the key-cutting machine. To ensure complete safety for the operator, any job not specified in this manual should be carried out by the manufacturer or in the special Service Centres recommended by Silca.

On the back cover of this manual is a list of the manufacturer's addresses; listed below are the addresses of specialised Service Centres.

Silca undertakes to make consumables, optional items and spare parts available for the limited time defined in its product obsolescence policy.

### **9.1 How to request service**

The guarantee attached to the key-cutting machines ensures free repairs or replacements of faulty parts within 24 months of purchase. All other service calls must be arranged by the customer with Silca or with a Silca service centre.



## EU DECLARATION OF MACHINE COMPLIANCE

**SILCA S.p.A. - VIA PODGORA 20 (Z.I.)  
31029 VITTORIO VENETO (TV) - (ITALY)  
TEL. 0438 9136 - FAX. 0438 913800**

Declares under its own responsibility that the **Key-Cutting Machine** models

**REKORD PRO  
REKORD PRO S  
REKORD PRO D12  
REKORD PRO AY**

comply with the requirements of the following European Directives:

European Union **DIRECTIVE 2006/42/EC** (Machinery)  
European Union **DIRECTIVE 2014/30/EU** (Electromagnetic Compatibility)  
European Union **DIRECTIVE 2014/35/EU** (Low Voltage)  
European Union **DIRECTIVE 2011/65/EU** (RoHS3)  
European Union **DIRECTIVE 2012/19/EU** (WEEE)

| 22 |

and with the following Standards:

EN 60335-1:2012 + AC:2014 + A11:2014 + A13:2017 + A1:2019 + A14:2019 + A2:2019 +  
A15:2021  
EN 62233:2008  
EN 62471:2008  
EN IEC 55014-1:2021; EN IEC 55014-2:2021; EN 55035:2017 + A11:2020  
EN IEC 61000-3-2:2019 + A1:2021  
EN 61000-3-3:2013 + A1:2019 + A2:2021 + A2/AC:2022

Silca S.p.A. R&D Division is authorized to create a Technical File.

CE

VITTORIO VENETO, 15/06/2022

CEO, Gazzola Michele

**SILCA S.p.A.**  
Via Podgora, 20 (Z.I.)  
31029 Vittorio Veneto (TV) Italy

A Member of the Kaba Group

Tel. +39 0438 9136 Fax +39 0438 913800 www.silca.it info@silca.it  
P. IVA C.F. e Reg. Impr. IT03286730266 REA TV 258111  
Cap. Soc. € 10.000.000 i.v. Export TV 038851

Società soggetta a direzione e coordinamento di Kaba Holding AG, con sede in Rümlang (Svizzera),  
Hofwisenstrasse 24, ai sensi e per gli effetti degli articoli 2497 - 2497sexies del Codice Civile.





## UKCA DECLARATION OF MACHINE COMPLIANCE

**SILCA S.p.A. - VIA PODGORA 20 (Z.I.)  
31029 VITTORIO VENETO (TV) - (ITALY)  
TEL. 0438 9136 - FAX. 0438 913800**

Declares under its own responsibility that the **Key-Cutting Machine** models

**REKORD PRO  
REKORD PRO S  
REKORD PRO D12  
REKORD PRO AY**

comply with the requirements of the following Statutory Instruments:

**Supply of Machinery (Safety) Regulations 2008  
Electromagnetic Compatibility Regulations 2016  
Electrical Equipment (Safety) Regulations 2016  
The Restriction of the Use of Certain Hazardous Substances in Electrical and Electronic  
Equipment Regulations 2012 (As amended)  
The Waste Electrical and Electronic Equipment Regulations 2013 (As amended)**

| 22 |

and with the following Standards:

BS EN 60335-1:2012 + AC:2014 + A11:2014 + A13:2017 + A1:2019 + A14:2019 +  
A2:2019 + A15:2021  
BS EN 62233:2008  
BS EN 62471:2008  
BS EN IEC 55014-1:2021; EN IEC 55014-2:2021; EN 55035:2017 + A11:2020  
BS EN IEC 61000-3-2:2019 + A1:2021  
BS EN 61000-3-3:2013 + A1:2019 + A2:2021 + A2/AC:2022

Silca S.p.A. R&D Division is authorized to create a Technical File.

**UK  
CA**

VITTORIO VENETO, 15/06/2022

CEO, Gazzola Michele  

**SILCA S.p.A.**  
Via Podgora, 20 (Z.I.)  
31029 Vittorio Veneto (TV) Italy

Tel. +39 0438 9136 Fax +39 0438 913800 www.silca.it info@silca.it  
P. IVA C.F. e Reg. Impr. IT03286730266 REA TV 258111  
Cap. Soc. € 10.000.000 i.v. Export TV 038851

**A Member of the Kaba Group**

Società soggetta a direzione e coordinamento di Kaba Holding AG, con sede in Rümliang (Svizzera),  
Hofwisenstrasse 24, ai sensi e per gli effetti degli articoli 2497 - 2497sexies del Codice Civile.

