

DELTA 2000 MC

Operating manual

D413875XA

vers. 3.0

EN



© 1998 SILCA S.p.A - Vittorio Veneto

This manual has been drawn up by SILCA S.p.A.

All rights reserved. No part of this publication may be reproduced or used in any form or by any means (photocopying, microfilm or other) without the written permission of SILCA S.p.A.

Edition: February 2008

*Printed in Vittorio Veneto
by SILCA S.p.A.
via Podgora, 20 (Z.I.)
31029 VITTORIO VENETO (TV) - Italy*

INDEX

1	TRANSPORT	3
1.1	Packing	3
1.2	Transport	3
1.3	Unpacking	3
1.4	Machine handling	3
2	WORKING PARTS	4
3	MACHINE DESCRIPTION	5
3.1	Technical data	6
3.2	Electrical circuit	7
4	ACCESSORIES PROVIDED	8
5	MACHINE INSTALLATION and PREPARATION	9
5.1	Checking for damage	9
5.2	Environmental conditions	9
5.3	Positioning	9
5.4	Description of work station	10
5.5	Separate parts	10
5.6	Connection to the mains	10
6	REGULATION and USE of the MACHINE	11
6.1	Checking and Setting	11
6.2	Setting	11
6.3	Cutting operations	12
6.4	Replacing the tip stop	12
7	MAINTENANCE	14
7.1	Cutting tool replacement	14
7.2	Brush replacement	14
7.3	Tracer point replacement	15
7.4	Replacing the fuses	15
8	DISPOSAL	16
9	ASSISTANCE	17
9.1	How to request service	17

GUIDE TO THE MANUAL

This manual has been produced to serve as a guide for users of the DELTA 2000 MC key-cutting machine. Read it carefully; it is essential if you wish to operate your machine safely and efficiently.

CONSULTATION

The contents of the manual are divided into sections relating to:

- Transport and handling	Chapter	1
- Description of machine and safety devices	Chapters	2-3-4-5
- Proper use of the machine	Chapters	5-6
- Maintenance	Chapter	7

TECHNICAL TERMS

Common technical terms are used in this manual. To assist those with little experience of key cutting, below is an illustration of the terms used for the different parts of keys:

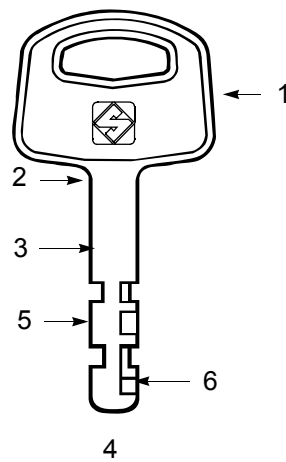

Fig. 1

- 1) Head
- 2) Rim
- 3) Stem
- 4) Tip
- 5) Back
- 6) Cuts

GENERAL INSTRUCTIONS

The DELTA 2000 MC key-cutting machine has been designed according to the specifications of the Machine Directives. From the design stage risks for the operator have been eliminated in all areas: transport, regulation, cutting and maintenance.

The use of protective goggles is compulsory during cutting operations, as indicated on the machine itself and in this manual.

The material used in the manufacture of this machine and the components employed during use of the machine are not dangerous and their use complies with standards.

USE

The DELTA 2000 MC key-cutting machine must be installed and used in the way laid down by the manufacturer, as illustrated in this manual.

If the machine is used differently or for purposes different from those described in this manual, the customer will forego any rights he may have over SILCA S.p.A. Furthermore, unforeseen danger to the operator or any third parties may arise from incorrect use of the machine.

Negligence in the use of the machine or failure on the part of the operator to observe the instructions given in this manual are not covered by the guarantee and the manufacturer declines all responsibility in such cases. It is therefore indispensable to read the operating manual carefully in order to make the best use of the DELTA 2000 MC key-cutting machine and benefit from its potential.

FURTHER RISKS

There are no further risks arising from the use of the DELTA 2000 MC key-cutting machine.

PROTECTION AND SAFETY PRECAUTIONS FOR THE OPERATOR

The DELTA 2000 MC key-cutting machine is built entirely to standards. The operations for which it has been designed are easily carried out at no risk to the operator.

The adoption of general safety precautions (use of protective goggles) and observation of the instructions provided by the manufacturer in this manual eliminate all human error, unless deliberate.

The DELTA 2000 MC key-cutting machine is designed with features which make it completely safe in all its parts.

• Power supply

The key-cutting machine must be supplied with electricity by means of a safety device (supplied with the 230V machines; on request for other voltages). The plug must be earthed.

• Start-up

The machine is started up by means of:

- the safety device switch supplied with the 230V machines);
- the ON switch, situated on the machine, which activates the machine motor.

• Maintenance

The operations to regulate, service, repair and clean the machine have been devised in the simplest and safest way possible. There is no danger of removable parts being replaced wrongly or unsafely.

• Machine identification

The DELTA 2000 MC is provided with an identification label which shows the serial number (fig. 2).

WARNING: should the machine be left on continuously for over 50 minutes, the cutting tool motor is protected against overheating and will automatically cut out. In such cases, proceed as follows:

- a) turn off the master switch (F);
- b) let the motor cool for at least 2 hours before using the machine again.

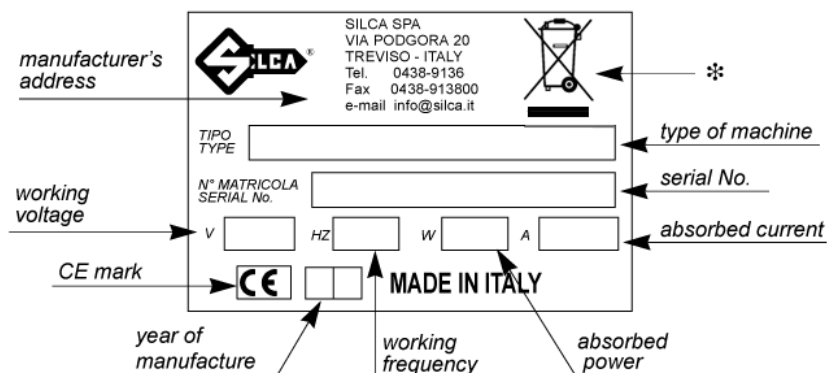

Fig. 2

(*) see chap.8 DISPOSAL, page 16.

1 TRANSPORT

The DELTA 2000 MC key-cutting machine is easily transported and is not dangerous to handle. The packed machine can be carried by one person.

1.1 Packing

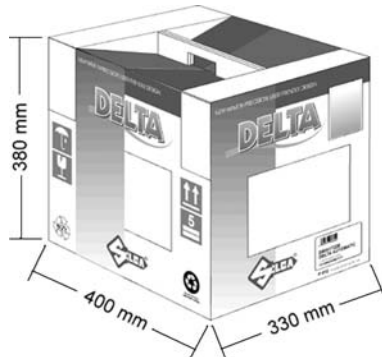

The DELTA 2000 MC key-cutting machine comes in a strong cardboard box, the dimensions of which are shown in fig. 3, designed to protect the machine and all its parts even when it is stored for long periods.

Fig. 3

1.2 Transport

It is advisable to use the packing every time the machine is transported, as this will avoid knocks which could cause damage to the machine, persons or things.

1.3 Unpacking

To remove the machine from the packing box, carefully follow the illustrated instructions below:

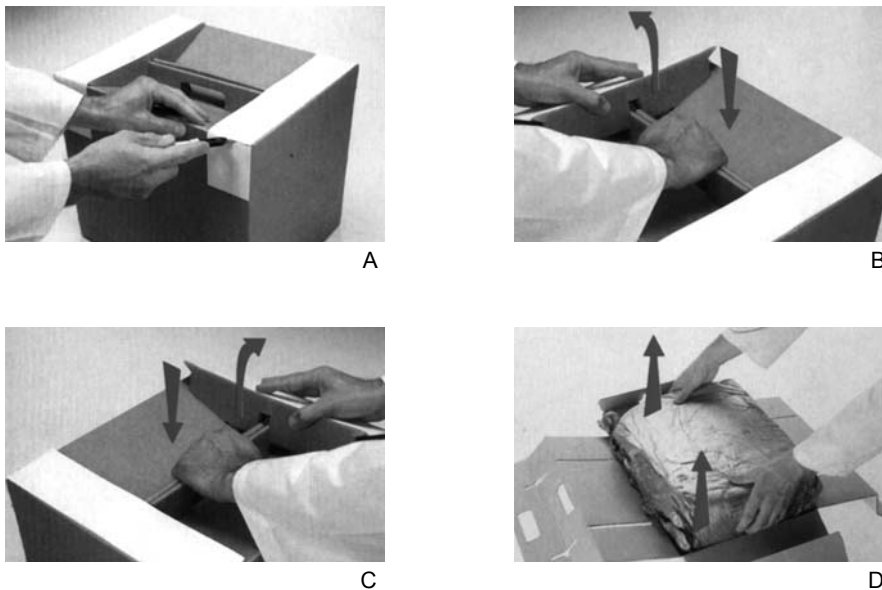

Fig. 4

Check the contents of the box, which should comprise:

- 1 DELTA 2000 MC key-cutting machine;
- 1 set of documents, including: operating manual, spare parts list and guarantee;
- 1 chippings tray;
- 1 power cable;
- 1 power supply safety device (supplied with the 230V machines)
- 1 set of accessories.

1.4 Machine handling

When the DELTA 2000 MC key-cutting machine has been unpacked, place it directly on its workbench. This operation can be carried out by one person, **firmly holding the base, and no other part, to lift and carry the machine.**

2 WORKING PARTS

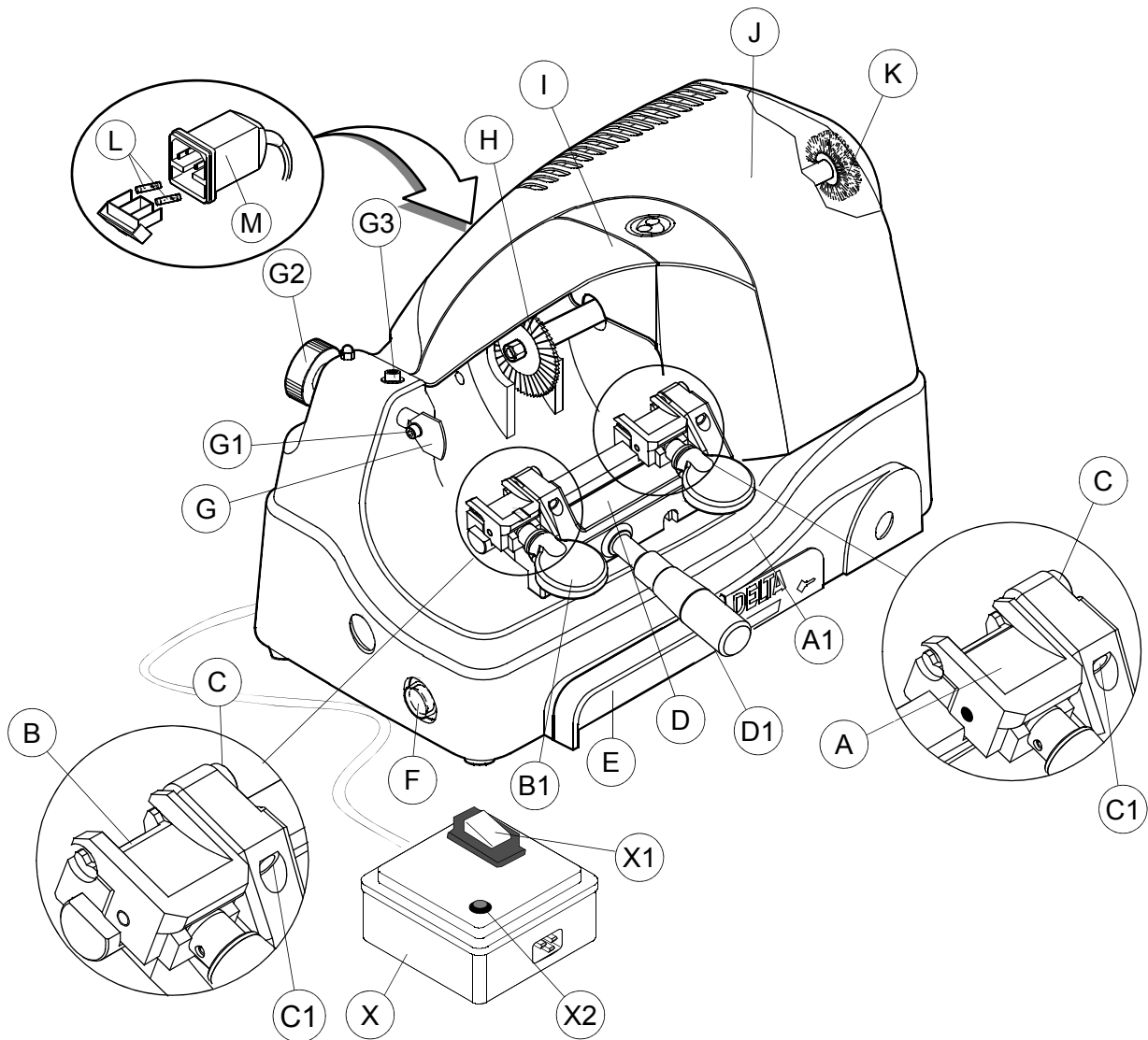

Fig. 5

- A - right-hand clamp
- A1- right-hand clamp knob
- B - left-hand clamp
- B1- left-hand clamp knob
- C - tip stop
- C1- tip stop grub screw
- D - carriage
- D1 - carriage lever handle
- E - chippings tray
- F - motor/brush start button
- G - tracer point
- G1- tracer point locking screw
- G2- tracer point adjusting nut
- G3- tracer point unit locking screw
- H - cutting tool
- I - cover
- J - motor
- K - brush
- L - fuses
- M - supply socket
- X - safety device (supplied with the 230V machines; on request for other voltages)
- X1- safety device main switch
- X2- warning light

3 MACHINE DESCRIPTION

DELTA 2000 MC is a professional key-cutting machine for keys such as FORD (FO19P, FO20P), ABLOY (left-hand cutting only, for al), ABUS (AB32, AB38P), AVA CHUBB (ACH, 5ACH4, 5ACH1). The machine comprises the following main parts:

SAFETY DEVICE (X)

The device is connected to a power plug with a differential switch. power the key-cutting machine by pressing the switch (X1) (fig. 6).

The warning light (X2) illuminates to indicate voltage in the plug (X3).

WARNING: Switch (X1) is electromagnetic, in the event of a power failure it goes out automatically. When electricity is restored it must be reset manually to power the machine again by means of the plug (X3).

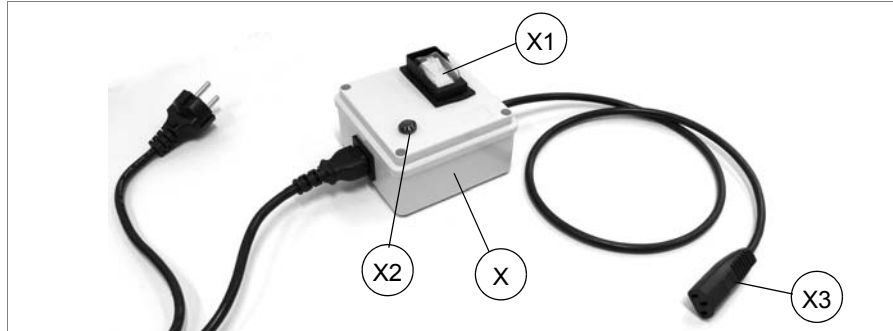

Fig. 6

MASTER SWITCH (F)

The motor and brush starting button (F) is placed on the left side of the DELTA 2000 MC key-cutting machine.

WARNING: the switch is constantly illuminated to indicate that the machine is live.

MOTOR (J)

The DELTA 2000 MC has a direct drive motor. The transmission unit comprises the motor, cutter and brush and is protected by a single cover (I).

MOBILE UNIT

The mobile unit comprises a carriage (D) which holds a single unit with two tilting jaws.

The carriage is fitted to the translation shaft and is moved manually by the operator. It is designed to prevent the accumulation of dust or cutting chips.

The key-cutting machine has a sloping table so that the chips will fall into the special tray (E) placed under carriage and easily removed in order to dispose of the waste.

- **Brush (K)**

The brush is used to eliminate burrs caused by the cutting process and is made of safe materials.

- **Cutting tool (H)**

The cutting tool is the part of the DELTA 2000 MC machine which cuts the key blank. The tool is in HSS super rapid steel and is protected by a special cover (I) to ensure safe operation.

- **Tracer point (G)**

The tracer point is housed on the left-hand side of the machine base. Its depth settings are easily regulated with the ring nut (G2).

- **Right-hand clamp (A)**

The right-hand jaw (A) houses the key to be cut and is fitted to the shaft, together with the left-hand jaw. The clamp unit is secured by means of a knob (A1), anatomically shaped to facilitate grip and control of the cutting operation.

- **Left-hand clamp (B)**

The left-hand jaw (B) houses the key to be copied and is secured by means of the knob (B1).

- **Tip stops (C)**

The interchangeable tip stops act as a reference for positioning the keys and are attached to the carriage by means of grub screws (C1).

3.1 **Technical data**

ELECTRICAL PROPERTIES: 230V - 50Hz 190W 1,5A

CUTTING TOOL: Super Rapid Steel (HSS)

MOTOR: One speed single phase 230V-50Hz 1350 rpm 0,145 Kw

CARRIAGE MOVEMENT: manual

CLAMPS: rocker

SAFETY DEVICE: supplied with the 230V machines; on request for other voltages

CARRIAGE RUN (maximum length of cuts): 23 mm

DIMENSIONS: width: 210 mm depth: 370 mm height: 250 mm

NOISE PRESSURE: Lp (A)= 92,2 dB (A)

NOISE POTENTIAL: Lw (A)= 104,9 dB (A)

WEIGHT: Kg. 14

3.2 Electrical circuit

The DELTA 2000 MC key-cutting machine is provided with a motor which performs at 1350 rpm with consumption of approx. 0,19 kw and absorption of 1,5A.

The main parts of the electrical circuit are listed below:

- 1) Safety device inlet
- 2) Safety main switch
- 3) Warning light
- 4) Wiring clip
- 5) Machine inlet
- 6) Rapid 3,15A fuses
- 7) Switch with lamp
- 8) Motor: 230V a.c. 50Hz
- 9) 6,3 μ F condenser

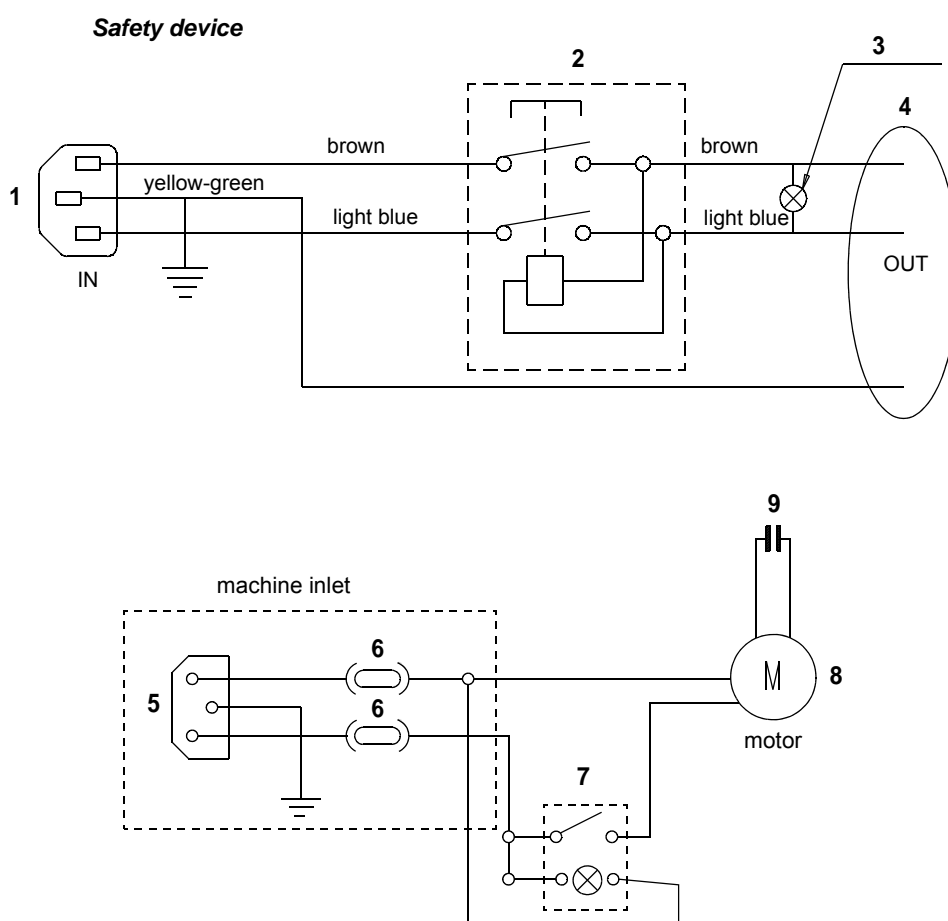







4 ACCESSORIES PROVIDED

To ensure trouble-free working with the DELTA 2000 MC, it is advisable to always have certain spare parts on hand.

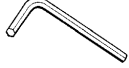
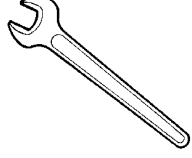
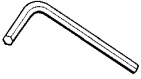
It is advisable to always have a tool box containing: tools, cutting tools, brushes and small replacement parts.

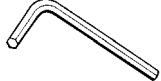
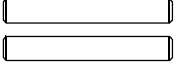
DELTA 2000 MC is supplied with a full range of accessories.

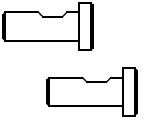
The accessories provided by Silca are all that is necessary to carry out the operations for which the machine is designed.

<p>1</p>  <p>code D300222ZZ 2,5 mm ALLEN KEY</p>	<p>6</p>  <p>code D312327ZZ 15 mm SPANNER</p>
<p>2</p>  <p>code D300223ZZ 3 mm ALLEN KEY</p>	<p>7</p>  <p>code D301760ZZ 17 mm SPANNER</p>
<p>3</p>  <p>code D300224ZZ 4 mm ALLEN KEY</p>	<p>8</p>  <p>code D200756ZZ SETTING PINS 2 pcs</p>
<p>4</p>  <p>code D302883ZZ 8 mm SPANNER</p>	<p>9</p>  <p>code D413433BA 3mm TIP STOPS 2 pcs</p>
<p>5</p>  <p>code D300308ZZ 10 mm SPANNER</p>	<p>10</p>  <p>code D309226ZZ 5x20 FUSES 3,15 Amps rapid 2 pcs</p>

5 MACHINE INSTALLATION AND PREPARATION

The DELTA 2000 MC key-cutting machine can be installed by the purchaser and does not require any special skills. However, some checks and preparation for use need to be carried out by the operator.

5.1 Checking for damage

The DELTA 2000 MC is solid and compact and will not normally damage if transport, unpacking and installation have all been carried out according to the instructions on the packing box. However, it is always advisable to check that the machine has not suffered any damage.

5.2 Environmental conditions

To ensure that the best use is made of the key-cutting machine, certain parameters must be borne in mind:

- damp, badly ventilated sites should be avoided.
- the conditions for the machine are:
 - temperature: between 0 and 40°C
 - relative humidity: approx. 60%

5.3 Positioning

Place the machine on a horizontal surface, solid enough to take the weight (14 Kg).

To facilitate operation and maintenance, install the machine with a clearance of at least 200 mm on all sides (fig. 7).

Check that the weight of the machine is evenly distributed over the four feet; horizontal positioning prevents vibrations during operation.

WARNING: ensure that the machine voltage is the same as that of the mains, which must be properly earthed and provided with a differential switch.

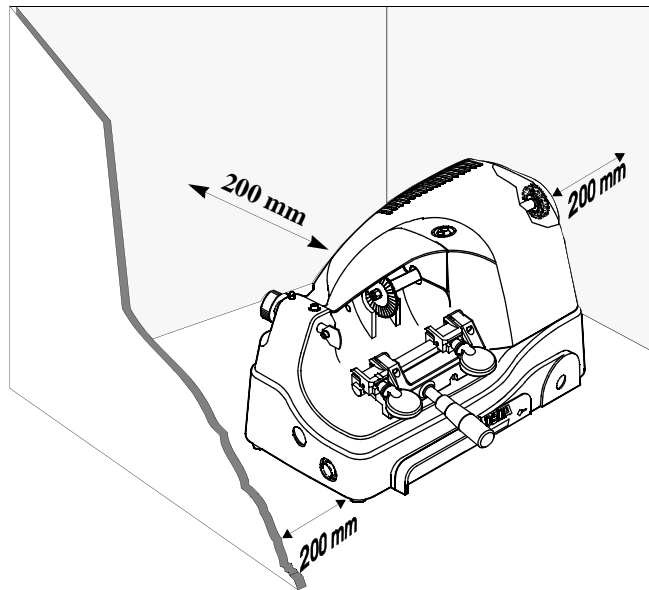

Fig. 7

5.4 Description of work station

The machine needs only one operator, who has the following controls at his/her disposal (fig. 8):

- Safety device (X).
- Master switch (F), placed on the left-hand side of the machine; provided with a warning light indicating that the machine is live.
- Carriage lever handle (D1).

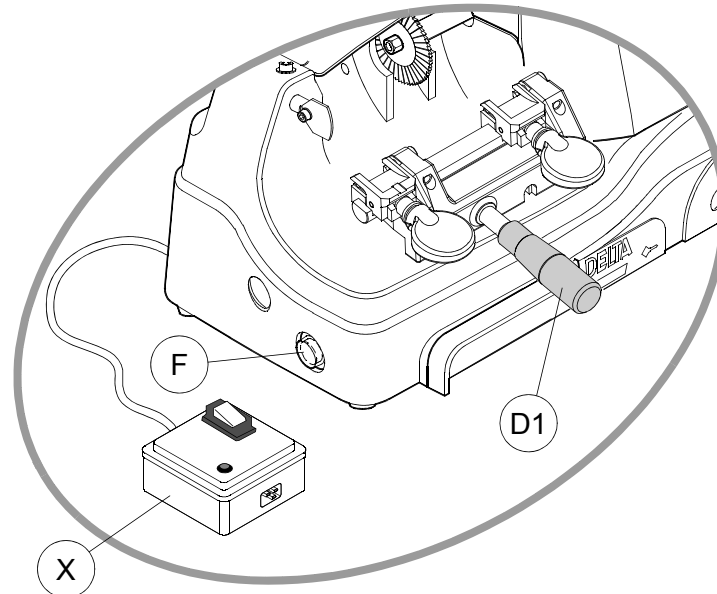

Fig. 8

5.5 Separate parts

The detachable parts of the machine are packed separately and must be fitted to the DELTA 2000 MC by the operator, as follows:

POWER CABLE

First connect the safety device (X) to the key-cutting machine and the power cable then connect the free end of the power cable to the power mains (fig. 9).

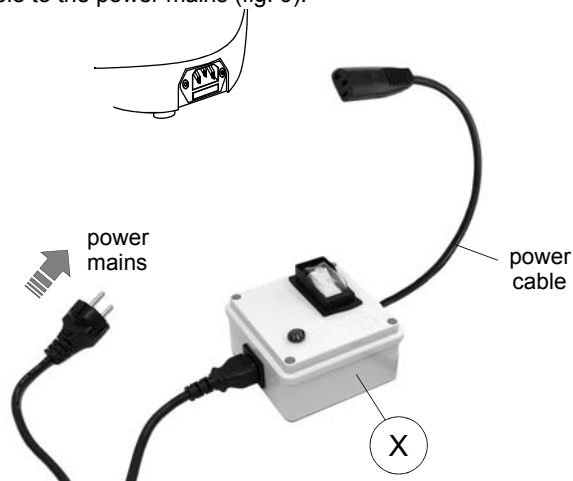

Fig. 9

5.6 Connection to the mains

It is extremely important for the operator's safety to ensure that the key-cutting machine is connected to the power mains with the right voltage and by means of a **properly earthed differential switch**.

6 REGULATION AND USE OF THE MACHINE

6.1 Checking and Setting

The cutting tool on the DELTA 2000 MC is used to cut the key blanks and must be periodically checked and replaced.

Periodically, and whenever the cutting tool is replaced, check the key-cutting machine settings, to ensure perfect machine efficiency.

6.2 Setting

AXIAL SETTING

Axial setting refers to adjustment of the distance between the tracer point position and cutting position (fig. 10-A). **The axis setting for the DELTA 2000 MC is fixed and is established on assembly in our workshops.**

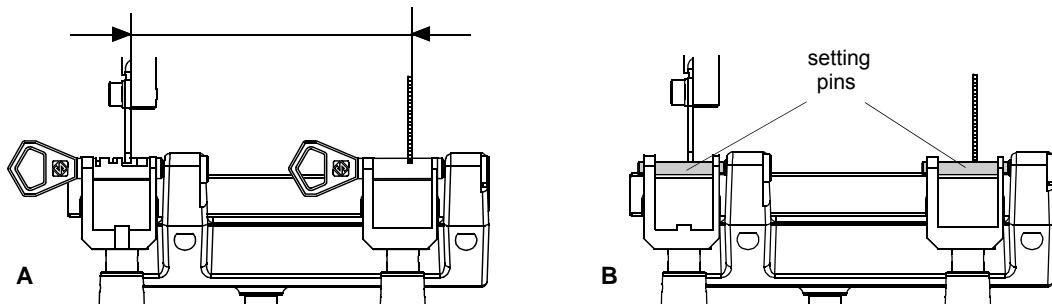

Fig. 10

DEPTH SETTING

Depth setting refers to adjustment of the alignment between the tracer point depth and the depth of the cuts.

To regulate the depth settings, proceed as follows:

WARNING: disconnect the machine from the mains.

- 1) place the setting pins (provided) on the clamps (fig. 10-B).
- 2) raise the carriage and take towards the tracer point and cutting tool until the pin on the left-hand clamp comes into contact with the tracer point.
- 3) turn the cutting tool anticlockwise by hand. Take the gauging pin on the left-hand clamp up to the tracer point and ensure that the cutting tool skims the pin on the right-hand clamp.
- 4) turn the right-hand clamp knob upwards and repeat the operation described above.
- 5) if necessary, regulate the cutting depth by means of the tracer point, as described below:
 - a) loosen the tracer point locking screw (G3) (fig. 11).
 - b) turn the adjusting nut (G2): clockwise to advance the tracer point (G), anticlockwise to move the tracer point back.
- 6) when regulation is complete, screw down the screw (G3) to lock the tracer point.
- 7) if the height of the tracer point must be adjusted, loosen screw (G1) and re-position manually.
- 8) when regulation is complete, screw down the screw (G1) to lock the tracer point.

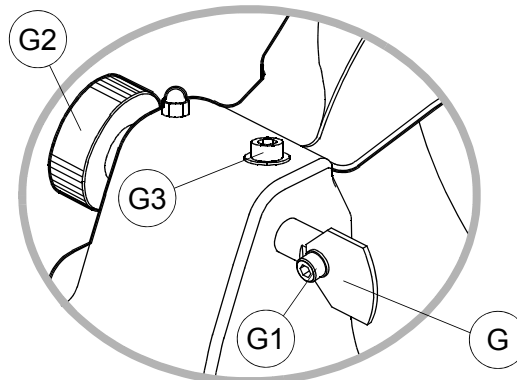

Fig. 11

6.3 Cutting operations

WARNING: to work in complete safety, pay special attention to the following recommendations:

- Always work with dry hands.
- Check that the machine is properly earthed.
- Use the protective goggles, even if the cutting tool is fitted with a protective shield.
- Start the motor only when all the operations with the carriage have been carried out (securing keys, etc.).
- Keep hands away from the cutting tool when in motion.

6.4 Replacing the tip stop

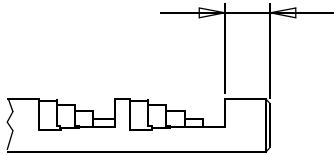

ABLOY keys can feature two types of cut which differ only in the distance between the first cut and the tip of the key. This distance can be 3 or 5 mm (fig. 12). The machine leaves our workshops set for the cutting of ABLOY keys with a distance of 5 mm between the tip and the first cut. To cut keys with a distance of 3mm the standard tip stops must be replaced with the ones provided.

Fig. 12

To do so, proceed as follows:

- 1) loosen the two grub screws (C1);
- 2) remove the 5 mm tip stops;
- 3) fit the 3 mm tip stops provided, positioning them as shown in fig. 13;
- 4) tighten the grub screws (C1), exerting slight pressure in the direction of the arrow on the tip stops.

FITTING KEYS INTO THE CLAMP

ABLOY - FO19P/FO20P:

Place the original key in the left-hand jaw, pushing towards the tip stop and secure by means of the knob (B1); the profile of the jaw ensures that the key is centred. Place the key blank in the right-hand jaw in the same way and secure by means of the knob (A1).

AB32 - AB38P:

Place the original key in the left-hand jaw (B), pushing towards the tip stop and against the side of the jaw (fig. 13); secure by means of the knob (B1). Place the key blank in the right-hand jaw (A) in the same way and secure by means of the knob (A1).

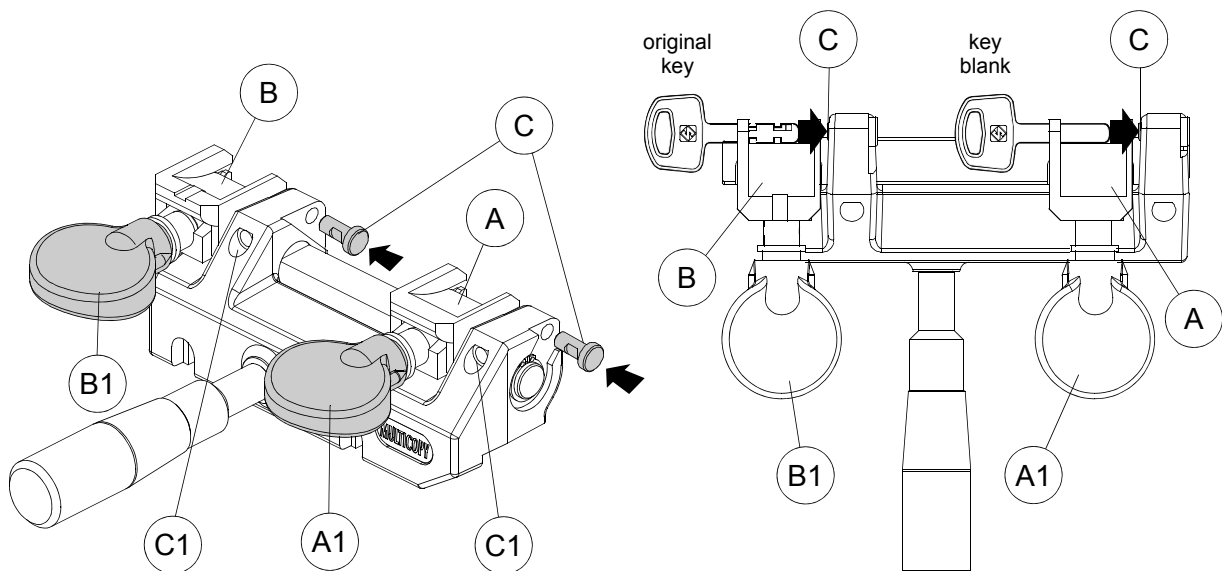

Fig. 13

KEY CUTTING

- 1) Fit the original key into the left-hand jaw (B) and secure in the way described above;
- 2) fit the key blank into the right-hand jaw (A) and secure in the way described above;
- 3) activate the machine by means of start button (F);
- 4) grip the lever (D1) with the left hand and the knob (A1) with the right hand;
- 5) push the carriage towards the cutting tool until it brings the original key into contact with the tracer point;
- 6) make a rotary movement downwards with the knob (A1) to copy the inclination of the cuts;
- 7) repeat the operation for each cut, if necessary adding a slight horizontal movement (fig. 14);
- 8) for keys cut on both sides, turn off the machine and turn both keys over, then repeat the operations described above;
- 9) when cutting is finished, turn off the machine and remove the keys from the clamp;
- 10) re-activate the machine with switch (F) and eliminate burrs with the brush (K).

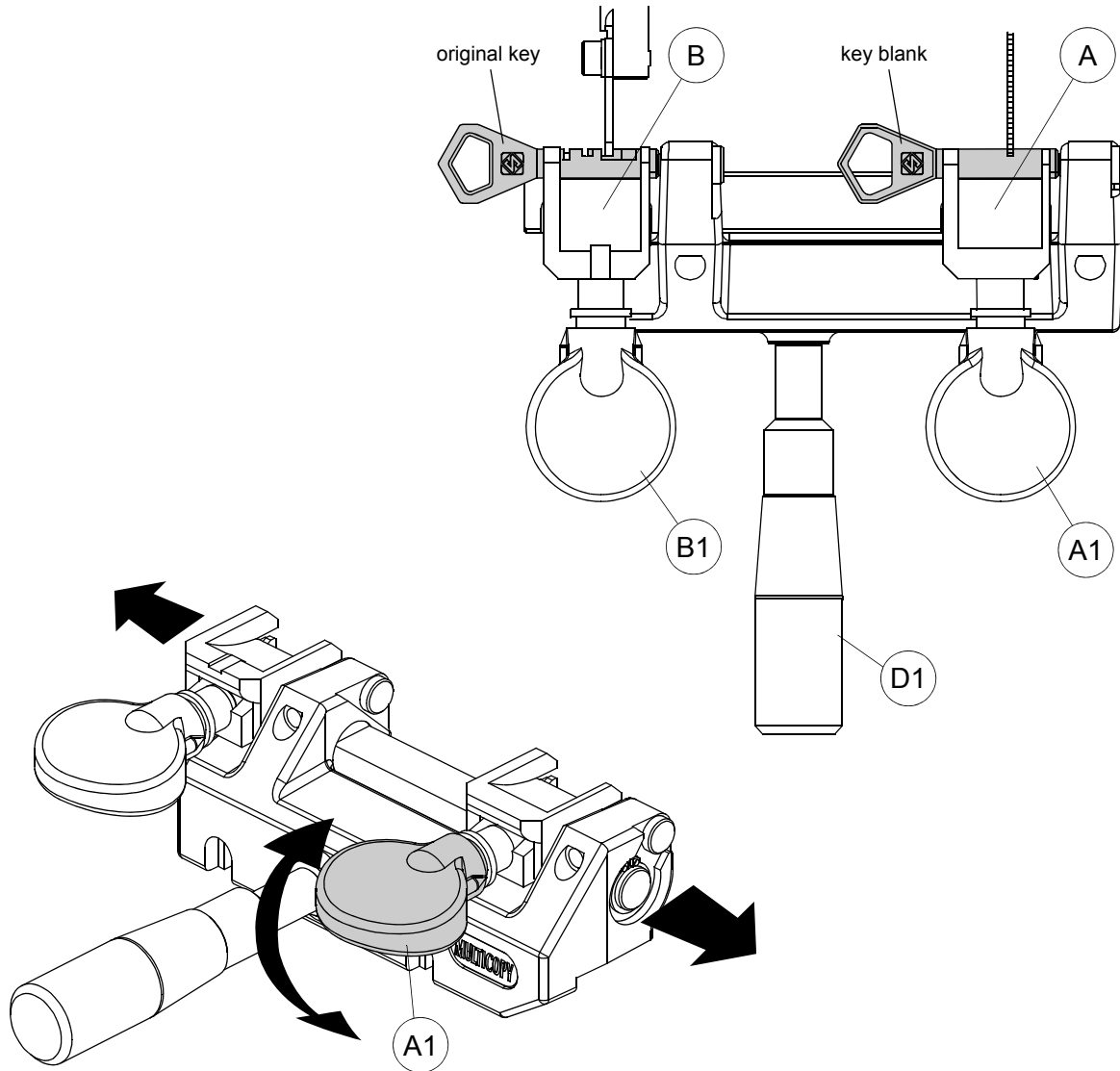

Fig. 14

7 MAINTENANCE

WARNING: for repairs or replacement of parts for maintenance, the 'CE' mark is guaranteed only if original spare parts provided by the manufacturer are used.

Although the DELTA 2000 MC key-cutting machine does not require special maintenance, it is advisable to check and, if necessary, replace the parts subject to wear (cutting tool, brush, tracer point).

Replacement is simple and can be carried out by the operator.

CLEANING: it is advisable to use a soft brush to keep the carriage and clamps free of chippings from cutting operations.

WARNING: DO NOT USE COMPRESSED AIR!

WARNING: to keep the machine well maintained we recommend using protective oil, e.g. WD40 or similar, applied to the burnished mechanical parts. This prevents oxidation of the parts in question (clamps, guides, carriages, etc.).

Before starting any type of maintenance (checks or replacements), read the instructions below:

- never carry out maintenance or servicing with the machine switched on.
- always remove the mains plug.
- follow all the instructions in the manual to the letter.
- use original spare parts.
- always check that any screws or nuts removed when replacing a piece are properly tightened.

7.1 Cutting tool replacement

It is not necessary to remove the protective shield in order to replace the cutting tool (H).

WARNING: unplug the machine from the mains.

- 1) place the spanner provided in position on the motor shaft (fig. 15);
- 2) use a suitable spanner to loosen the new cutting tool locking nut.

WARNING: the thread is left-handed.

- 3) replace the cutting tool after cleaning its seat;
- 4) install the new cutting tool and tighten the nut.

WARNING: the tool rotates clockwise.

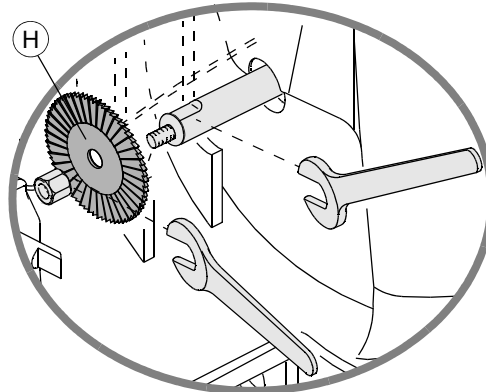

Fig. 15

7.2 Brush replacement

When the brush (K) is no longer effective it must be replaced, as follows:

WARNING: unplug the machine from the mains.

- 1) place the spanner provided in position on the motor shaft (fig. 15);
- 2) use the wrench provided to loosen the brush locking screw (fig. 16);
- 3) replace the brush and secure with the screw;
- 4) remove the spanner from the motor shaft.

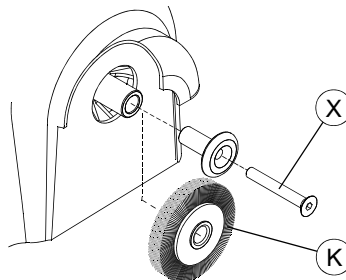

Fig. 16

7.3 Tracer point replacement

To replace the tracer point (G), proceed as follows (fig. 17):

WARNING: unplug the machine from the mains.

- 1) loosen and remove the tracer point locking screw (G1).
- 2) remove the tracer point.
- 3) fit the new tracer point.
- 4) re-gauge the machine as described in Ch. 6, page 11.

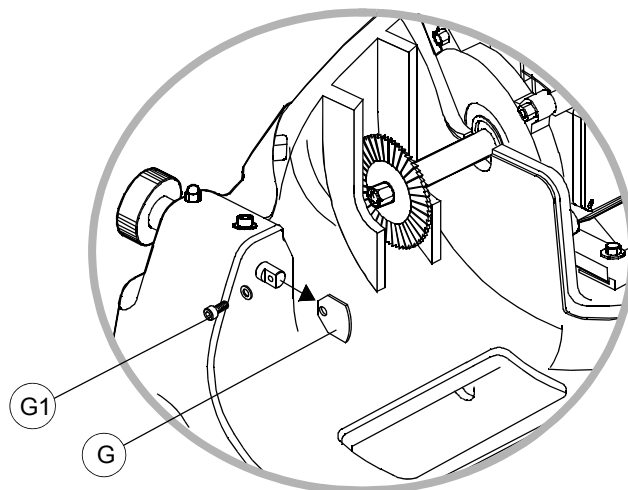

Fig. 17

7.4 Replacing the fuses

WARNING: unplug the machine from the mains.

- 1) detach the wiring from the machine plug;
- 2) turn the key-cutting machine so that the fuse box is easily reached;
- 3) remove the fuse box placed below the power inlet (M) (fig. 18);
- 4) replace the fuses (L);
- 5) close the fuse box and connect the power cable.

WARNING: the fuses must both be of the same type (rapid) and with the same amps (3,15 Ampere).

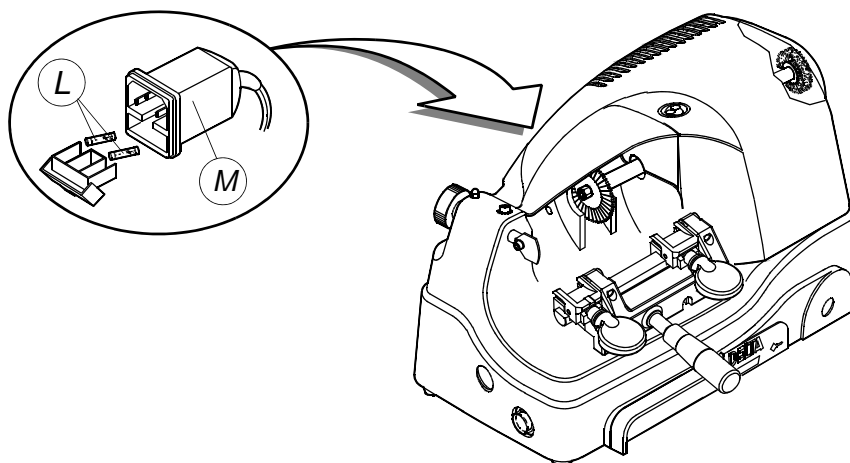

Fig. 18

8 DISPOSAL

For correct disposal please refer to current standards.

INFORMATION FOR USERS OF PROFESSIONAL EQUIPMENT



From "Actuation of Directive 2012/19/EU regarding Waste Electrical and Electronic Equipment (WEEE)"

The symbol of a crossed waste bin found on equipment or its packing indicates that at the end of the product's useful life it must be collected separately from other waste so that it can be properly treated and recycled.

In particular, separate collection of this professional equipment when no longer in use is organised and managed:

- a) directly by the user when the equipment was placed on the market before 31 December 2010 and the user personally decides to eliminate it without replacing it with new equivalent equipment designed for the same use;
- b) by the manufacturer, that is to say the subject which was the first to introduce and market new equipment that replaces previous equipment, when the user decides to eliminate equipment placed on the market before 31 December 2010 at the end of its useful life and replace it with an equivalent product designed for the same use. In this latter case the user may ask the manufacturer to collect the existing equipment;
- c) by the manufacturer, that is to say the subject which was the first to introduce and market new equipment that replaces previous equipment, if it was placed on the market after 31 December 2010;

Suitable separate collection for the purpose of forwarding discarded equipment for recycling, treatment or disposal in an environmentally friendly way helps to avoid possible negative effects on the environment and human health and encourages re-use and/or recycling of the materials making up the equipment.

The sanctions currently provided for by law shall apply to users who dispose of products in unauthorised ways.

9 ASSISTANCE

Silca provides full assistance to purchasers of the DELTA 2000 MC key-cutting machine.

To ensure complete safety for the operator, any job not specified in this manual should be carried out by the manufacturer or in the special Service Centres recommended by Silca.

On the back cover of this manual is a list of the manufacturer's addresses; listed on the next page are the addresses of specialised Service Centres.

9.1 How to request service

The guarantee attached to DELTA 2000 MC key-cutting machine ensures free repairs or replacements of faulty parts within 24 months of purchase. All other service calls must be arranged by the customer with Silca or with a Silca Service Centre.



VITTORIO VENETO 24/03/2011

CE DECLARATION OF MACHINE COMPLIANCE

**SILCA S.p.A. - VIA PODGORA 20 (Z.I.)
31029 VITTORIO VENETO (TV) - (ITALY)
TEL. 0438 9136 - FAX. 0438 913800**

Declares under its own responsibility that the **Key-cutting machine** model

DELTA MULTI COPY

complies with the requirements of the following European Directives:

European Union **DIRECTIVE 2006/42/CE** (Machines)
and with the EN 292/1 – EN 292/2 Standards

European Union **DIRECTIVE 2004/108/CE** (Electromagnetic Compatibility)
and with the EN 55022 - IEC 801-2 - IEC 801-4 Standards

European Union **DIRECTIVE 2006/95/CE** (Low Voltage)
and with the EN 60204-1 - EN 60950 Standards

| 97 |

Claudio Tomasella of the Silca S.p.A. Research & Development Division is authorized to create a Technical File.

General Manager Basic Production Center

Stefano Setti

SILCA S.p.A.
Via Podgora, 20 (Z.I.)
31029 Vittorio Veneto (TV) Italy

A Member of the Kaba Group

Tel. +39 0438 9136 Fax +39 0438 913800 www.silca.it info@silca.it
P. IVA C.F. e Reg. Impr. IT03286730266 REA TV 258111
Cap. Soc. € 10.000.000 i.v. Export TV 038851

Società soggetta a direzione e coordinamento di Kaba Holding AG, con sede in Rümlang (Svizzera),
Hofwisenstrasse 24, ai sensi e per gli effetti degli articoli 2497 - 2497sexies del Codice Civile.

